

UNITED STATES PATENT AND TRADEMARK OFFICE

BEFORE THE PATENT TRIAL AND APPEAL BOARD

MYLAN PHARMACEUTICALS INC. and PFIZER INC.,¹
Petitioner,

v.

SANOFI-AVENTIS DEUTSCHLAND GMBH,
Patent Owner.

IPR2018-01682
Patent 9,526,844 B2

Before HYUN J. JUNG, BART A. GERSTENBLITH, and
JAMES A. TARTAL, *Administrative Patent Judges*.

TARTAL, *Administrative Patent Judge*.

JUDGMENT
Final Written Decision
Determining All Challenged Claims Unpatentable
Denying Patent Owner's Motion to Amend
Denying Petitioner's Motion to Exclude
35 U.S.C. § 318(a)

¹ Pfizer Inc. was joined as a petitioner in this proceeding.

We have jurisdiction to conduct this *inter partes* review under 35 U.S.C. § 6. This Final Written Decision is issued pursuant to 35 U.S.C. § 318(a) and 37 C.F.R. § 42.73. For the reasons discussed herein, we determine that a preponderance of the evidence shows that claims 21–30 (the “Challenged Claims”) of U.S. Patent 9,526,844 B2 (Ex. 1004, “the ’844 patent”) are unpatentable. We deny the motion to amend claims filed by Sanofi-Aventis Deutschland GmbH (“Patent Owner”).² We also deny the motion to exclude.

I. INTRODUCTION

A. Summary of Procedural History

Mylan Pharmaceuticals Inc. (“Mylan”)³ filed a Petition (Paper 2, “Pet.”) requesting *inter partes* review of the Challenged Claims. Pet. 1. We instituted an *inter partes* review of the Challenged Claims on all grounds of unpatentability asserted in the Petition. Paper 19 (“Inst. Dec.”). After institution, Pfizer Inc. (“Pfizer”)⁴ separately filed a petition challenging the same claims of the ’844 patent on the same grounds asserted by Mylan, along with a motion for joinder to this case. *Pfizer Inc. v. Sanofi-Aventis Deutschland GmbH*, IPR2019-01023, Papers 2, 3 (May 2, 2019). We instituted *inter partes* review on Pfizer’s petition and granted Pfizer’s motion for joinder. Paper 45.

² Patent Owner identifies itself, Sanofi-Aventis U.S. LLC, and Sanofi Winthrop Industrie as real parties in interest. Paper 5, 2.

³ Mylan identifies itself, Mylan Inc., Mylan GmbH (Mylan N.V. subsidiaries), Biocon Research Ltd., Biocon Ltd., and Becton, Dickinson and Company as real parties in interest. Pet. 1; Paper 7, 2.

⁴ Pfizer identifies itself and Hospira, Inc., as real parties in interest. *Pfizer Inc. v. Sanofi-Aventis Deutschland GmbH*, IPR2019-01022, Paper 2, 1.

Patent Owner filed a Patent Owner Response (Paper 30, “PO Resp.”). Mylan and Pfizer (collectively, “Petitioner”) filed a Reply to the Patent Owner Response (Paper 50, “Pet. Reply”), to which Patent Owner filed a Sur-reply (Paper 65, “PO Sur-reply”).

Patent Owner also filed a Corrected Revised Contingent Motion to Amend (Paper 71, “RMTA”).⁵ Petitioner filed an Opposition to the RMTA (Paper 78, “RMTA Opp.”), to which Patent Owner filed a Reply (Paper 88, “RMTA Reply”), and further to which Petitioner filed a Sur-reply (Paper 95, “RMTA Sur-reply”).

Patent Owner filed Observations on the Cross Examination of Mr. Karl Leinsing. Paper 82. Petitioner filed Observations Regarding the Testimony of Alexander Slocum, Ph.D. Paper 83. Patent Owner filed a Response to Petitioner’s Observations (Paper 84) and Petitioner filed a Response to Patent Owner’s Observations (Paper 85).

Petitioner filed a Motion to Exclude (Paper 90, “Mot.”). Patent Owner filed a Response in opposition to the Motion to Exclude (Paper 93, “Mot. Opp.”), to which Petitioner filed a Reply (Paper 94, “Mot. Reply”).

Oral argument was held and a transcript of the hearing appears in the record. Paper 102 (Tr.). We have jurisdiction under 35 U.S.C. § 6. This Final Written Decision is issued pursuant to 35 U.S.C. § 318(a) and 37 C.F.R. § 42.73 (2017). Petitioner bears the burden of proving unpatentability of the Challenged Claims by a preponderance of the evidence, and the burden of persuasion never shifts to Patent Owner. *See*

⁵ Prior to filing its Corrected Revised Contingent Motion to Amend, Patent Owner filed a Contingent Motion to Amend (Paper 32), to which Petitioner filed an opposition (Paper 52), and further to which we issued Preliminary Guidance (Paper 62).

IPR2018-01682
Patent 9,526,844 B2

35 U.S.C. § 316(e) (2012); 37 C.F.R. § 42.1(d) (2017); *Dynamic Drinkware, LLC v. Nat'l Graphics, Inc.*, 800 F.3d 1375, 1378 (Fed. Cir. 2015).

B. Related Proceedings

Claims 21–30 of the '844 patent are also challenged by Mylan in IPR2018-01680, to which Pfizer was joined as petitioner based on its petition in IPR2019-01022. Patent Owner also filed a Corrected Revised Contingent Motion to Amend in IPR2018-01680 that, along with the related briefing of the parties, is substantively the same as the RMTA and related briefing filed in this case. Mylan also challenged the same claims of the '844 patent in IPR2018-01696, however, institution of *inter partes* review in that proceeding was denied.

The parties identify the following court proceedings as related matters:

Sanofi-Aventis U.S. LLC, Sanofi-Aventis Deutschland GmbH, Sanofi Winthrop Industrie v. Mylan GmbH, Biocon Ltd., Biocon Research Ltd., Biocon Sdn. Bhd. and Biocon S.A., Case No. 2-17-cv-09105-SRC-CLW (D.N.J.) (the “NJ-9105 Case”);

Sanofi-Aventis U.S. LLC, Sanofi-Aventis Deutschland GmbH, and Sanofi Winthrop Industrie v. Merck Sharp & Dohme Corp., Case No. 1-16-cv-00812-RGA-MPT (D. Del.); and

Sanofi-Aventis U.S. LLC, Sanofi-Aventis Deutschland GmbH v. Eli Lilly and Company, Case No. 1-14-cv-00113-RGA-MPT (D. Del.).

Pet. 1–2; Paper 5, 2; Exs. 1029, 1030. On March 9, 2020, the court in the NJ-9105 Case issued an order finding that “Mylan has proven that [claims 21, 22, 25, and 30 of the '844 patent] are invalid for failure to satisfy the written description requirement stated in 35 U.S.C. § 112 ¶ 1.”

Ex. 1118, 1–2.

According to the parties, patents related to the '844 patent are challenged in IPR2018-01670, IPR2018-01675, IPR2018-01676, IPR2018-01677, IPR2018-01678, IPR2018-01679, IPR2018-01684, IPR2019-00122, IPR2019-00977, IPR2019-00978, IPR2019-00979, IPR2019-00980, IPR2019-00981, IPR2019-00982, and IPR2019-00987. Pet. 2; Paper 5, 2–3; Paper 7, 2–3; Paper 24, 2–4; Paper 56, 1–3. Patent Owner also identifies numerous U.S. patents and U.S. patent applications that claim priority to one or more of the same applications to which the '844 patent claims priority. Paper 5, 4–5; Paper 24, 5–6; Paper 56, 3–5.

C. The '844 Patent

The '844 patent, titled “Pen-Type Injector,” issued December 27, 2016, from an application filed May 17, 2016. Ex. 1004, codes (54), (45), (22). The '844 patent “relates to pen-type injectors . . . where a user may set the dose.” *Id.* at 1:25–29. We next provide a claim of the '844 patent to illustrate the subject matter followed by a description of the apparatus disclosed.

1. Illustrative Claim

Challenged claim 21 is independent. Challenged claims 22–30 depend from claim 21. Claim 21 is illustrative of the claimed subject matter and is reproduced below:

21. A drug delivery device comprising:
 - a housing comprising a dose dispensing end and a first thread;
 - a dose indicator comprising a second thread that engages with the first thread;
 - a driving member comprising a third thread;
 - a sleeve that is (i) disposed between the dose indicator and the driving member and (ii) releasably connected to the dose indicator;
 - a piston rod comprising either an internal or an external fourth thread that is engaged with the third thread;

a piston rod holder that is rotatably fixed relative to the housing and configured to (i) prevent the piston rod from rotating during dose setting and (ii) permit the piston rod to traverse axially towards the distal end during dose dispensing;

wherein:

the housing is disposed at an outermost position of the drug delivery device;

the dose indicator is disposed between the housing and the sleeve and is configured to (i) rotate and traverse axially away from the dose dispensing end during dose setting and (ii) rotate and traverse axially towards the dose dispensing end during dose dispensing;

the driving member is configured to rotate relative to the piston rod;

the sleeve is rotatably fixed relative to the driving member and configured to traverse axially with the dose indicator; and

the piston rod and the driving member are configured to rotate relative to one another during dose dispensing; and

the piston rod is configured to traverse axially towards the dose dispensing end during dose dispensing.

Ex. 1004, 8:16–49.

2. *Description of the Apparatus Disclosed*

Figures 1 and 2 of the '844 patent are reproduced below, as annotated by Petitioner with color-coding of certain components that Petitioner contends correspond to the features recited in claim 21 of the '844 patent.

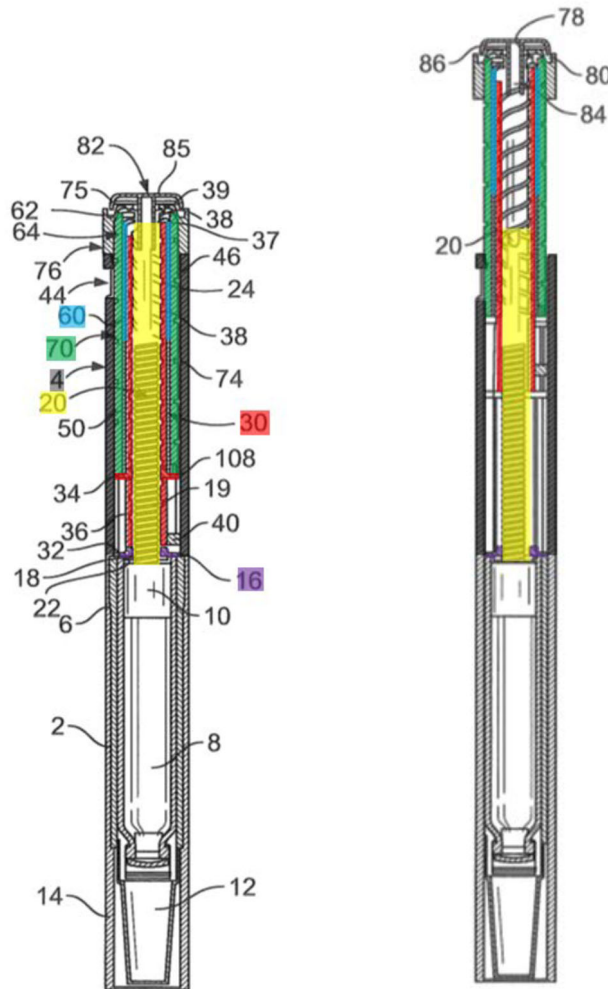

Pet. 6–7. Figure 1 (left) and Figure 2 (right) illustrate “a sectional view of a pen-type injector” in a “cartridge full” position in Figure 1 and in a “maximum first dose dispensed” position in Figure 2. Ex. 1004, 2:60–62. As explained by Petitioner, the injector includes main housing part 4 (grey) (the recited “housing”), dose-dial sleeve 70 (green) (the recited “dose indicator”), drive sleeve 30 (red) (the recited “driving member”), clutch 60 (blue) (the recited “sleeve”), piston rod 20 (yellow) (the recited “piston rod”), and insert 16 (purple) (the recited “piston rod holder”).⁶ Pet. 4–7;

⁶ Petitioner notes that the ’844 patent refers to the needle-end of the device as the “first end” or “distal end” and to the button-end as the “second end” or “proximal end.” Pet. 8 n.2 (citing Ex. 1004, 3:8–14, claim 1).

Ex. 1004, 3:37–38, 3:59–62, 4:13–23, 4:42–44. Patent Owner similarly provides a summary of the components shown in Figures 1 and 2, further highlighting medicament cartridge 8, cartridge piston 10, clicker 50, externally-grooved dose dial sleeve 70, dose dial grip 76, and button 82. PO Resp. 7–8.

As shown in Figures 1 and 2, insert 16 is at a first end of housing part 4 and is fixed rotationally and axially to housing part 4. Ex. 1004 at 3:58–59. Insert 16 includes threaded circular opening 18, through which piston rod 20 extends. *Id.* at 3:59–62. Piston rod 20 includes first thread 19 that engages threaded circular opening 18. *Id.* at 3:65–4:1. Piston rod 20 also includes pressure foot 22 that abuts piston 10 of cartridge 8. *Id.* at 4:1–3. Drive sleeve 30 extends about piston rod 20, and second thread 24 of piston rod 20 engages internal helical groove 38 of drive sleeve 30. *Id.* at 4:13–23.

Clicker 50 and clutch 60 are disposed between drive sleeve 30 and dose-dial sleeve 70. *Id.* at 4:42–44. Clicker 50 is generally cylindrical and includes, at one end, extending arm 52 and, at the other end, saw teeth 56. *Id.* at 4:46–53. Clutch or clutch means 60 includes, at one end, saw teeth 66, which interface with saw teeth 56. *Id.* at 4:59–61, Fig. 7. Clutch 60 is generally cylindrical and includes a radially inwardly directed flange 62 and dog teeth 65 at the end opposite of saw teeth 66. *Id.* at 4:63–67. Clutch 60 is keyed to drive sleeve 30 by splines to prevent relative rotation between clutch 60 and drive sleeve 30. *Id.* at 5:2–4.

Dose-dial sleeve 70 is outside of clutch 60 but within housing 4. *Id.* at 5:12–14. Dose-dial sleeve 70 has helical groove 74 on its outer surface, and helical rib 46 of housing 4 is seated in helical groove 70 to allow relative motion. *Id.* at 5:14–20. Dose-dial grip 76 is disposed about the second end

of dose-dial sleeve 70 and secured to dose-dial sleeve 70 to prevent relative motion. *Id.* at 5:34–39.

In operation, a user rotates dose-dial grip 76 to set a dose and to cause dose-dial sleeve 70, clutch 60, and drive sleeve 30 to rotate together out of housing part 4. *Id.* at 5:60–64, Fig. 9. The dose can be reduced by turning dose-dial grip 76 in the opposite direction. *Id.* at 6:28–30, Fig. 10.

Clicker 50 and clutch 60 provide audible and tactile feedback of the dose being dialed, as torque is transmitted through the saw teeth 56, 66. *Id.* at 5:64–66. Flexible arm 52 deforms and drags toothed member 54 over splines 42 to produce a click. *Id.* at 5:67–6:2. Splines 42 may be configured such that each click corresponds to a unit dose. *Id.* at 6:2–2. Once the proper dose is set, the user then presses button 82, which causes clutch 60 to disengage from dose-dial sleeve 70 so that clutch 60 moves axially and dose-dial sleeve 70 rotates back into housing part 4. *Id.* at 6:38–45, Fig. 11. Drive sleeve 30 also moves axially and causes piston rod 20 to rotate through threaded opening 18 to dispense medicine from cartridge 8. *Id.* at 6:55–57. Drive sleeve 30 is prevented from rotating by the deformation of flexible arm 52, such that saw teeth 56, 66 are not overhauled during dispense. *Id.* at 6:46–48.

D. References and Expert Testimony

Below we provide an abbreviated summary of the qualifications of each expert that provides testimony on behalf of one of the parties in this case. We also provide a table identifying the references relied upon, as well as the exhibits corresponding to the declarations and deposition testimony in the record for each expert.

Petitioner's contentions are supported by Mr. Karl R. Leinsing, MSME, PE; Dr. William C. Biggs; and Dr. DeForest McDuff, Ph.D.

Mr. Leinsing is the President of a company that develops medical devices, previously worked as a Director of Biomedical Engineering at a company that developed implants for heart valve repair, previously worked as a Senior Principal Design Engineer on medical drug infusion products from 1992 to 2002, and has Bachelor of Science and Master of Science degrees in mechanical engineering. Ex. 1011 ¶¶ 2–6.

Dr. Biggs has been “Board Certified by the American Board of Internal Medicine in Internal Medicine since 1985,” is a Clinical Assistant Professor in the Department of Internal Medicine at Texas Tech School of Medicine, is the Medical Director of the Diabetes Center at Northwest Texas Hospital, and works “as the Principal Investigator for numerous clinical research trials involving diabetes for type 1 and type 2 diabetes, including trials that look specifically at the effect of insulins, devices, patient education, and healthcare costs.” Ex. 1048 ¶¶ 3–13.

Dr. McDuff has undergraduate degrees in economics and mathematics and a Ph.D. in economics, is a Partner at an economics consulting firm, and has “provided expert analysis and consulting in over 50 cases involving pharmaceuticals and related products, including evaluations of economic damages, competition, commercial success, irreparable harm, and other issues.” Ex. 1060 ¶¶ 1–4.

Patent Owner’s arguments are supported by Dr. Alexander H. Slocum, Ph.D.; Dr. Henry G. Grabowski, Ph.D.; and Dr. Robin S. Goland. Dr. Slocum is a Professor of Mechanical Engineering at the Massachusetts Institute of Technology, has “taught courses on mechanical design, including precision machine design, continuously since 1991,” has “taught courses on medical device design continuously since 2001,” is a consultant “for companies to assist them with various types of design challenges,” is “an

inventor on approximately 133 United States patents, many of which relate to machine elements, tools, and medical devices,” and has Bachelor of Science and Master of Science degrees in mechanical engineering and a Doctor of Philosophy degree. Ex. 2107 ¶¶ 3–13.

Dr. Grabowski is Professor Emeritus of Economics and the Director of the Program in Pharmaceuticals and Health Economics at Duke University, much of his “research has focused on pharmaceutical competition and the economics of generic medications,” and he has a Bachelor of Science degree in engineering physics and a doctorate in economics. Ex. 2109 ¶¶ 1–4.

Dr. Goland is “board-certified in Internal Medicine and Endocrinology,” has been the Chief of the Diabetes Clinic at New York-Presbyterian Hospital/Columbia University since 1987, is a Professor of Clinical Medicine, Clinical Medicine and Clinical Pediatrics, and Clinical Diabetes, and is “an experienced clinical investigator and principal investigator in diabetes trials.” Ex. 2111 ¶¶ 2–7.

References and Expert Testimony	Date	Exhibit No.
US 6,235,004 B1 (“Steenfeldt-Jensen”)	May 22, 2001	Ex. 1014
US 6,582,404 B1 (“Klitgaard”)	June 24, 2003	Ex. 1017
US 6,932,794 B2 (“Giambattista”)	Aug. 23, 2005	Ex. 1016
US 2002/0053578 A1 (“Møller”)	May 2, 2002	Ex. 1015
WO 02/092153 (“Atterbury”)	Nov. 21, 2002	Ex. 1097
US 4,648,872 (“Kamen”)	Mar. 10, 1987	Ex. 2169
US 4,747,824 (“Spinello”)	May 31, 1988	Ex. 2170
US 6,248,093 B1 (“Moberg”)	June 19, 2001	Ex. 2171
Declaration of Karl R. Leinsing, MSME, PE	Sept. 9, 2018	Ex. 1011

References and Expert Testimony (con't)	Date	Exhibit No.
Reply Declaration of Karl R. Leinsing, MSME, PE	Sept. 18, 2019	Ex. 1095
Declaration of Karl R. Leinsing, MSME, PE, Supporting Opposition to Motion to Amend	Sept. 18, 2019	Ex. 1096
Declaration of Karl R. Leinsing, MSME, PE, Supporting Opposition to Revised Motion to Amend	Dec. 17, 2019	Ex. 1113
Deposition Transcript of Karl R. Leinsing, MSME, PE	June 3, 2019	Ex. 2163
Deposition Transcript of Karl R. Leinsing, MSME, PE	June 4, 2019	Ex. 2164
Deposition Transcript of Karl R. Leinsing, MSME, PE	Oct. 10, 2019	Ex. 2316
Deposition Transcript of Karl R. Leinsing, MSME, PE	Dec. 20, 2019	Ex. 2331
Declaration of Dr. William C. Biggs	Sept. 16, 2019	Ex. 1048
Deposition Transcript of Dr. William C. Biggs	Oct. 15, 2019	Ex. 2317
Declaration of DeForest McDuff, Ph.D.	Sept. 17, 2019	Ex. 1060
Deposition Transcript of DeForest McDuff, Ph.D.	Oct. 9, 2019	Ex. 2318
Declaration of Alexander H. Slocum, Ph.D. in Support of Patent Owner Response	June 24, 2019	Ex. 2107
Declaration of Alexander H. Slocum, Ph.D. in Support of Motion to Amend	June 24, 2019	Ex. 2302
Declaration of Alexander H. Slocum, Ph.D. in Support of Revised Motion to Amend	Oct. 30, 2019	Ex. 2325
Declaration of Alexander H. Slocum, Ph.D. in Support of Reply for Revised Motion to Amend	Jan. 7, 2020	Ex. 2332

References and Expert Testimony (con't)	Date	Exhibit No.
Deposition Transcript of Alexander H. Slocum, Ph.D.	Aug. 27, 2019	Ex. 1053
Deposition Transcript of Alexander H. Slocum, Ph.D.	Aug. 28, 2019	Ex. 1054
District Court Trial Testimony Transcript of Alexander H. Slocum, Ph.D.	Dec. 4, 2019	Ex. 1114
District Court Trial Testimony Transcript of Alexander H. Slocum, Ph.D.	Dec. 5, 2019	Ex. 1115
Deposition Transcript of Alexander H. Slocum, Ph.D.	Dec. 10, 2019	Ex. 1109
Deposition Transcript of Alexander H. Slocum, Ph.D.	Jan. 10, 2020	Ex. 1117
Declaration of Henry G. Grabowski, Ph.D.	June 22, 2019	Ex. 2109
Deposition Transcript of Henry G. Grabowski, Ph.D.	Sept. 5, 2019	Ex. 1055
Declaration of Dr. Robin S. Goland	June 24, 2019	Ex. 2111
Deposition Transcript of Robin S. Goland	Sept. 10, 2019	Ex. 1056

E. The Asserted Grounds of Unpatentability

Petitioner alleges unpatentability of the Challenged Claims on the following grounds:

Claim(s) Challenged	35 U.S.C. §	Reference(s)
21–29	103	Steenfeldt-Jensen
30	103	Steenfeldt-Jensen, Klitgaard

F. Date of Priority for the Challenged Claims of the '844 Patent

The '844 patent issued December 27, 2016, from U.S. Application No. 15/156,616 (“the '616 application”), filed May 17, 2016. Ex. 1004, codes (21), (22), (45). The '616 application was a continuation of U.S. Application No. 14/946,203 (“the '203 application”), filed November 19,

2015, which, itself, was one in a series of U.S. continuation and division applications dating back to March 2, 2004. *Id.* at code (60). The '844 patent also identifies under "Foreign Application Priority Data" a filing date of March 3, 2003, for Great Britain patent application number 0304822.0 (Ex. 1026, "the GB application"). *Id.* at code (30).

Petitioner argues that each of the Challenged Claims "lacks written description support under §112" in any of the priority documents and "is not entitled to a priority date earlier than May 17, 2016." Pet. 14–17. Specifically, Petitioner argues that "[e]ach of claims 21–30 of the '844 patent lacks support in the '203 application as well as the filings to which the '203 application claims priority for a 'piston rod' comprising an internal fourth thread that is engaged with a third thread of a 'driving member.'" *Id.* at 15–16.

In the Institution Decision, the Board did not need to address the effective filing date of the '844 patent because Patent Owner conceded that the asserted references in this case, Steinfeldt-Jensen and Klitgaard, are prior art to the '844 patent regardless of whether the '844 patent has priority to the GB application. *See* Inst. Dec. 23 (citing Paper 13 (Patent Owner arguing in its Preliminary Response that the '844 patent was entitled to claim priority to the GB application, but stating that "neither Patent Owner nor the Board needs to address this issue in this case," because Patent Owner concedes that Steinfeldt-Jensen and Klitgaard are prior art to the '844 patent). After institution, Patent Owner did not address in its Patent Owner's Response Petitioner's contention that the priority date for the Challenged Claims is May 17, 2016. *See generally* PO Resp.

In IPR2018-01680, we are issuing, contemporaneously, a final written decision in which we determine that Petitioner demonstrates that the Challenged Claims are not entitled to a priority date prior to May 17, 2016, the filing date of the '616 application.

II. ANALYSIS OF PETITION

In our analysis of Petitioner's unpatentability contentions with respect to the Challenged Claims, we next address the applicable principles of law; the level of ordinary skill in the art; the proposed construction of claim terms; the scope and content of the asserted prior art; and then further analyze Petitioner's contentions with respect to each alleged ground of unpatentability for purposes of determining whether Petitioner shows by a preponderance of the evidence the unpatentability of the Challenged Claims.

A. Principles of Law

Petitioner's two asserted grounds of unpatentability are based on obviousness. Pet. 3. A patent claim is unpatentable as obvious if "the differences between" the claimed subject matter "and the prior art are such that the subject matter as a whole would have been obvious at the time the invention was made to a person having ordinary skill in the art to which said subject matter pertains." 35 U.S.C. § 103(a).⁷ An invention "composed of several elements is not proved obvious merely by demonstrating that each of its elements was, independently, known in the prior art." *KSR Int'l Co. v. Teleflex Inc.*, 550 U.S. 398, 418 (2007).

⁷ The Leahy-Smith America Invents Act ("AIA"), Pub. L. No. 112-29, 125 Stat. 284, 287–88 (2011), amended 35 U.S.C. § 103 effective March 16, 2013. We quote the AIA version of 35 U.S.C. § 103, which applies to applications with an effective filing date after March 16, 2013, however, the pre-AIA version of § 103 is nearly identical and any differences do not affect our analysis here.

The question of obviousness is resolved on the basis of underlying factual determinations, including: (1) the scope and content of the prior art; (2) any differences between the claimed subject matter and the prior art; (3) the level of skill in the art; and (4) objective evidence of nonobviousness. *Graham v. John Deere Co. of Kansas City*, 383 U.S. 1, 17–18 (1966). An obviousness determination “cannot be sustained by mere conclusory statements; instead, there must be some articulated reasoning with some rational underpinning to support the legal conclusion of obviousness.” *KSR*, 550 U.S. at 418 (quoting *In re Kahn*, 441 F.3d 977, 988 (Fed. Cir. 2006)); see *In re Magnum Oil Tools Int’l, Ltd.*, 829 F.3d 1364, 1380 (Fed. Cir. 2016). Rather, “it can be important to identify a reason that would have prompted a person of ordinary skill in the relevant field to combine the elements in the way the claimed new invention does.” *Id*

B. Level of Ordinary Skill in the Art

In determining whether an invention would have been obvious at the time it was made, 35 U.S.C. § 103 requires us to resolve the level of ordinary skill in the pertinent art at the time of the invention. *Graham*, 383 U.S. at 17. The person of ordinary skill in the art is a hypothetical person who is presumed to have known the relevant art at the time of the invention. *In re GPAC, Inc.*, 57 F.3d 1573, 1579 (Fed. Cir. 1995).

Petitioner proposes that a person having ordinary skill in the art would have “had, through education or practical experience, at least the equivalent of a bachelor’s degree in mechanical engineering, or a related field” and “would have understood the basics of medical-device design and manufacturing, and basic mechanical elements (*e.g.*, gears, pistons) involved in drug-delivery devices.” Pet. 17–18 (citing Ex. 1011 ¶ 106). Patent Owner proposes a similar level of ordinary skill in the art and states that any

difference from Petitioner’s proposal is immaterial to the arguments presented. PO Resp. 11–12. Based on the evidence provided, including the prior art of record, we agree with Petitioner’s proposed level of ordinary skill and also find that the prior art of record further reflects the level of ordinary skill in the art. *See Okajima v. Bourdeau*, 261 F.3d 1350, 1355 (Fed. Cir. 2001) (noting that the prior art of record may reflect the level of ordinary skill in the art).

C. Claim Construction

In an *inter partes* review, “[a] claim in an unexpired patent . . . shall be given its broadest reasonable construction in light of the specification of the patent in which it appears.” 37 C.F.R. § 42.100(b) (2017); *Cuozzo Speed Techs., LLC v. Lee*, 136 S. Ct. 2131, 2142 (2016) (upholding the use of the broadest reasonable interpretation standard).⁸ “Under a broadest reasonable interpretation, words of the claim must be given their plain meaning, unless such meaning is inconsistent with the specification and prosecution history.” *TriVascular, Inc. v. Samuels*, 812 F.3d 1056, 1062 (Fed. Cir. 2016). If the Specification “reveal[s] a special definition given to a claim term by the patentee that differs from the meaning it would otherwise possess[,] . . . the inventor’s lexicography governs.” *Phillips v. AWH Corp.*, 415 F.3d 1303,

⁸ Although the claim construction standard applied in *inter partes* review was changed to the federal court claim construction standard used in a civil action under 35 U.S.C. § 282(b), that change does not apply to this proceeding because the Petition was filed before November 13, 2018, the effective date of the change. *See Changes to the Claim Construction Standard for Interpreting Claims in Trial Proceedings Before the Patent Trial and Appeal Board*, 83 Fed. Reg. 51,340, 51,344 (Oct. 11, 2018) (now codified at 37 C.F.R. pt. 42 (2019)).

1316 (Fed. Cir. 2005) (en banc) (citing *CCS Fitness, Inc. v. Brunswick Corp.*, 288 F.3d 1359, 1366 (Fed. Cir. 2002)).

Petitioner asserts that “claim terms should be given their ordinary and accustomed meaning, consistent with the specification and how they would have been understood by” a person having ordinary skill in the art. Pet. 18. Petitioner also asserts that Patent Owner has taken claim construction positions for certain claim terms in district court proceedings, and that the broadest reasonable interpretation of those terms should at least encompass Patent Owner’s proposed constructions in district court. *Id.* at 19.

In particular, Petitioner identifies the terms in the table below and provides definitions based on Patent Owner’s district court contentions.

Claim Term	Proposed Meaning (supporting citation)
“driving member”	“A component releasably connected to the dose dial sleeve that drives the piston during dose dispensing.” (Ex. 1019, 28.)
“main housing”	“An exterior unitary or multipart component configured to house, fix, protect, guide, and/or engage with one or more inner components.” (<i>Id.</i> at 21.)
“piston rod”	“A rod that engages with the driving member to advance the piston during dose dispensing.” (<i>Id.</i> at 27.)
“the piston rod and the driving member are configured to rotate relative to one another during dose dispensing”	Plain and ordinary meaning such that “during dose dispensing, the piston rod rotates while the driving member does not rotate, the driving member rotates while the piston rod does not rotate, or both rotate at different rates and/or directions.” (<i>Id.</i> at 27 (citing Ex. 1004, 6:38–67, FIG. 11; claim 21)).
“thread”	“A rib or groove on a first structure that engages a corresponding groove or rib on a second structure.” (<i>Id.</i> at 30.)

Claim Term	Proposed Meaning (supporting citation)
“clutch”	“A structure that couples and decouples a moveable component from another component.” (<i>Id.</i> at 24.)
“clicker”	“A structure that provides audible and/or tactile feedback when the dose knob is rotated.” (<i>Id.</i> at 31.)
“holder”	Plain and ordinary meaning such that a person of ordinary skill in the art “would understand to be ‘a structure that holds a referenced structure’ (e.g., a piston rod holder holds a piston rod).” <i>Id.</i> at 33.

Pet. 19–20. Petitioner also states that, in district court proceedings, Mylan proposed means-plus-function constructions for the terms “clutch,” “clicker,” and “holder.” *Id.* at 20. Petitioner identifies the functions and structures related to these three terms. *See id.* at 20–22.

Patent Owner does not propose alternative constructions and maintains that “no express constructions are required” to demonstrate that the Challenged Claims are patentable over the asserted prior art. PO Resp. 11. We agree with Patent Owner that no claim term requires express construction. *See Wellman, Inc. v. Eastman Chem. Co.*, 642 F.3d 1355, 1361 (Fed. Cir. 2011) (“claim terms need only be construed ‘to the extent necessary to resolve the controversy’” (internal citation omitted)). In as much as claim 22, or any other claim, must be construed to some extent, we address it in our patentability analysis below.

D. Scope and Content of the Prior Art

Petitioner relies on Steinfeldt-Jensen and Klitgaard to show the unpatentability of the Challenged Claims. Each of these references is summarized briefly below.

1. *Summary of Steinfeldt-Jensen*

Steenfeldt-Jensen, titled “Injection Syringe,” issued May 22, 2001, from an application filed October 28, 1999. Ex. 1014, codes (54), (45), (22). Steinfeldt-Jensen relates to “injection syringes of the kind apportioning set doses of a medicine from a cartridge . . . [and] are mainly made for users who have to inject themselves frequently, e.g. diabetics.” *Id.* at 1:12–17.

Petitioner relies primarily on the embodiment illustrated in Figures 15–17 of Steinfeldt-Jensen, the fifth of five embodiments described in Steinfeldt-Jensen, which the parties appropriately refer to as “the fifth embodiment.” *See* Ex. 1014, 4:60–5:28 (describing illustrations corresponding to five embodiments); Pet. 22 n.9; PO Resp. 14; Pet. Reply 5).

Figures 15–17 of Steinfeldt-Jensen are reproduced below:

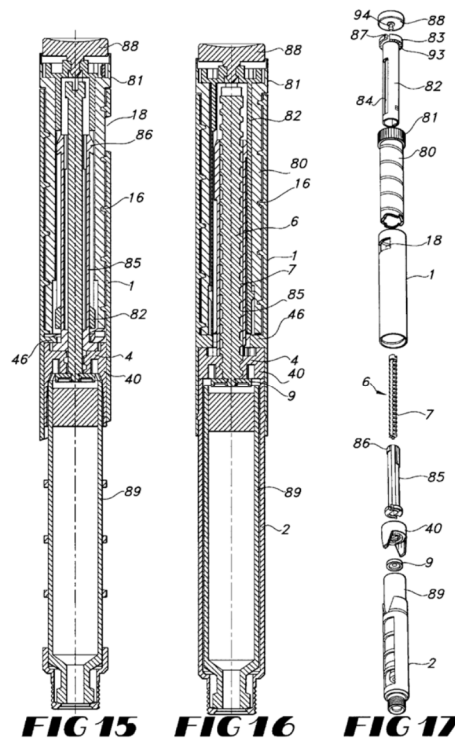

Figure 15 illustrates “a sectional side view” of an injection syringe, Figure 16 illustrates a “sectional side view perpendicular to the view in

[Figure] 15,” and Figure 17 depicts “an exploded view of the syringe in [Figures] 15 and 16.” Ex. 1014; *Id.* at 5:23–28. The injection syringe includes tubular housing 1 that is partitioned so that a first division has ampoule holder 2. *Id.* at 5:38–40. Ampoule holder 2 has a central bore with thread 5 that engages external thread 7 of piston rod 6. *Id.* at 5:55–58. Driver tube 85 is disposed about piston rod 6. *See id.* at Figs. 15–17. “The piston rod has a not round cross-section and fits through the driver tube bore which has a corresponding not round cross-section” so that “rotation is transmitted” and “the piston rod is allowed to move longitudinally through the driver tube.” *Id.* at 11:15–19.

Scale drum 80 within housing 1 has on its outer wall a helical track that engages a helical rib on the inner wall of housing 1. *Id.* at 11:20–22. One end of scale drum 80 has a larger diameter so as to form dose setting button 81. *Id.* at 11:22–24. Bushing 82 fits within scale drum 80 and over driver tube 85. *Id.* at 11:26–29. Bushing 82 is coupled to driver tube 85 so that both bushing 82 and driver tube 85 can rotate, but not move longitudinally. *Id.* at 11:30–33. Injection button 88 is rotatably mounted at an end of bushing 82. *Id.* at 49–51. A dose is set by rotating dose setting button 81, which causes scale drum 80 to rotate out of housing 1. *Id.* at 11:52–55. Injection button 88 is pressed to inject the set dose, and bushing 82 rotates with dose setting button 81, because of the engagement of the helical track of scale drum 80 with the rib of housing 1 when scale drum 80 is pressed into housing 1. *Id.* at 12:4–10. The rotation of bushing 82 rotates driver tube 85, causing piston rod 6 to rotate and screw into ampoule 89 in ampoule holder 2. *Id.* at 12:10–13.

Steenfeldt-Jensen also teaches audible and tactile clicks formed when setting the dose that represent one unit of dose. Specifically, Steenfeldt-Jensen states as follows:

To set a dose the ampoule holder 2 is rotated anticlockwise in the first division of the housing 1. This rotation is performed against a resistance presented due to the fact that a protrusion 30 on the outer wall of the ampoule holder rests in one of a number of depressions 31 circumferentially provided in the inner wall of said first division of the housing as shown in the cross-sectional view in FIG. 3. The angular spacing of the depressions are appropriately made so that a dose of one unit is set when the protrusion is moved from one depression to the [neighboring] depression so that the number of clicks heard and felt during the dose setting rotation corresponds to the size of the set dose.

Id. at 6:42–53.

2. Summary of Klitgaard

Klitgaard, titled “Dose Setting Limiter,” issued June 24, 2003, from an application filed September 6, 2000. Ex. 1017, codes (54), (45), (22). Klitgaard is directed to “injection devices where[] the contents of a cartridge are injected as a number of individually set doses.” *Id.* at 1:13–15. Figure 3 of Klitgaard is reproduced below:

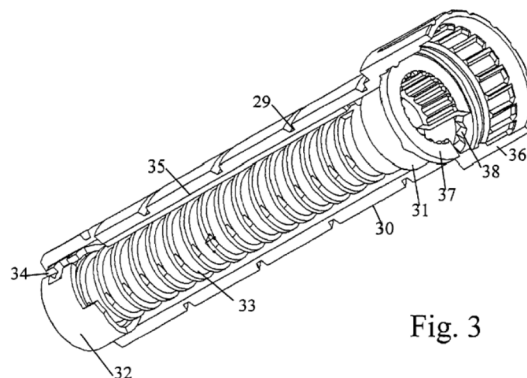

Fig. 3

Figure 3 illustrates “the dose setting member, the driver, and the track follower of an[] embodiment of an injection syringe.” *Id.* at 2:60–63. Relevant to our decision, Klitgaard discloses nut member 32, which is

disposed between dose setting-member 30 and driver 31. *Id.* at 4:26–29. During dose setting, nut member 32 rotates with dose-setting element 30 relative to driver 31 because of the engagement between ridge 35 and recess 34, such that the position of nut member 32 on driver 31 depends on the set dose. *Id.* at 4:33–37. When the medicine is injected, dose-setting member 30 is forced to rotate relative to the housing and transmits rotational force to driver 31, but nut member 32 maintains its position on driver 31, such that the position indicates the total injected dose. *Id.* at 4:37–58.

E. Alleged Obviousness over Steinfeldt-Jensen

Petitioner contends that claims 21–29 of the '844 patent would have been obvious over Steinfeldt-Jensen. Pet. 26–68; Pet. Reply 1–21. Patent Owner argues that certain limitations of claims 21 and 22 are not taught or suggested by Steinfeldt-Jensen, and that a person of ordinary skill in the art would not have been motivated to modify Steinfeldt-Jensen. PO Resp. 21–41; PO Sur-reply 1–15. We address each of the Challenged Claims below and determine for the reasons provided that Petitioner shows by a preponderance of the evidence that Steinfeldt-Jensen teaches or suggests every limitation of claims 21–29 of the '844 patent and demonstrates a persuasive rationale in support of the proposed modification.

1. Differences Between the Subject Matter of Independent Claim 21 and the Teachings of Steinfeldt-Jensen

Petitioner provides claim charts and arguments with citations to where Steinfeldt-Jensen teaches or suggests the limitations of claim 21, along with citations to the supporting declaration of Mr. Leinsing. Pet. 56 (citing Ex. 1011 ¶¶ 612–642, 644, 646, 647, 649–652, 654–657). Patent Owner primarily argues that Steinfeldt-Jensen fails to teach or suggest the recited

“driving member comprising a third thread.” *See* PO Resp. 21–26. We address each limitation of claim 21 below.

a) A drug delivery device comprising:

To the extent that the preamble is limiting, Petitioner shows, and Patent Owner does not dispute, that Steinfeldt-Jensen teaches an “injection syringe” that “relates to injection syringes of the kind apportioning set doses of a medicine from a cartridge containing an amount of medicine sufficient for the preparation of a number of therapeutic doses,” corresponding to the recited “drug delivery device.” Pet. 26–27 (quoting Ex. 1014, Abstract, 1:12–15). We are persuaded that Petitioner shows by a preponderance of the evidence that Steinfeldt-Jensen teaches the preamble, to the extent it is limiting, based on the reasons and evidence identified in the portions of the Petition cited in the preceding sentence, which we adopt as our own findings.

b) a housing comprising a dose dispensing end and a first thread;

Petitioner shows, and Patent Owner does not dispute, that Steinfeldt-Jensen teaches an injection syringe with tubular housing 1 into which ampoule holder 2 is snapped, corresponding to the recited “housing comprising a dose dispensing end,” and “a helical protruding rib 16 . . . defining an inner thread” on the inner wall of housing 1, corresponding to the recited “first thread.” Pet. 27–29 (citing Ex. 1014, 3:34–44, 6:7–11, 11:20–22, Figs. 15–17). We are persuaded that Petitioner shows by a preponderance of the evidence that Steinfeldt-Jensen teaches this limitation based on the reasons and evidence identified in the portions of the Petition cited in the preceding sentence, which we adopt as our own findings.

c) a dose indicator comprising a second thread that engages with the first thread;

Petitioner shows, and Patent Owner does not dispute, that Steinfeldt-Jensen teaches scale drum 80 corresponding to the recited “dose indicator.” Pet. 29–31. Petitioner explains that scale drum 80 includes a helical track, corresponding to the recited “second thread,” that engages the helical protruding rib 16 on the inner wall of housing 1, i.e., the “first thread.” *Id.* (citing Ex. 1014, 6:7–11, 6:18–21, 7:11–13, 11:20–22, Figs 15–17; Ex. 1011 ¶¶ 615–617); *see also* Ex. 1014, 11:20–22 (stating that “scale drum 80 is in its outer wall provided with a helical track which is engaged by a helical rib 16 along the inner wall of the housing 1”). Petitioner also notes that “Steenfeldt-Jensen explains that analogous elements in different embodiments are provided with the same reference number,” (citing Ex. 1014, 7:49–51), and that “[a]s can be seen in [Figure] 17 of Steinfeldt-Jensen, the embodiment shown in that figure has window 18, thus scale drum 80 also serves as a dose indicator.” Pet. 31.

We are persuaded that Petitioner shows by a preponderance of the evidence that Steinfeldt-Jensen teaches this limitation based on the reasons and evidence identified in the portions of the Petition cited in the preceding paragraph, which we adopt as our own findings.

d) a driving member comprising a third thread;

Petitioner contends that it would have been obvious to a person of ordinary skill in the art to modify the “piston rod drive” taught by Steinfeldt-Jensen to include a “driving member comprising a third thread,” as recited. Pet. 34. The parties agree that the fifth embodiment of Steinfeldt-Jensen, illustrated in Figures 15–17, upon which Petitioner primarily relies, does not show a “driving member comprising a third

thread.” Most useful on this point is the annotated illustration provided by Patent Owner of a cropped portion of Figure 17 of Steinfeldt-Jensen, which we reproduce below.

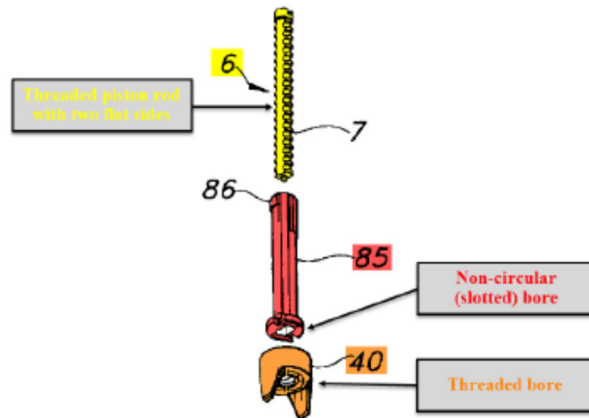

Ex. 1014, Fig. 17 (cropped and annotated)

PO Resp. 15. The portion of Figure 17 reproduced above shows, in an exploded view, piston rod 6 with external threading 7 (yellow), driver tube 85 (red), and member 40 (orange), which Patent Owner identifies as a “threaded bore,” from the fifth embodiment of Steinfeldt-Jensen. *Id.* Driver tube 85 is not shown to be threaded.

Petitioner explains, in regard to the fifth embodiment, that Steinfeldt-Jensen describes syringes with “a ‘piston rod drive’ that includes driver tube 85 (a sleeve rotationally coupled to the piston rod due to its unthreaded, non-circular cross-section) and member 40 (an element that has a threaded circular opening and that is fixed to the housing).” Pet. 33 (citing Ex. 1014, Abstract, 2:46–53, claims 1, 6, 11; Ex. 1011 ¶ 618). Petitioner acknowledges that “[t]o drive piston rod 6, driver tube 85 rotationally engages with the rod through a bore having a non-circular cross-section, rather than an internal threading near a distal portion.” Pet. 34 (citing Ex. 1011 ¶ 620). Thus, driver tube 85 is a “driving member,” but driver tube 85 does not comprise a “third thread.” Petitioner argues that a person

of ordinary skill in the art “would have considered it obvious to modify the piston rod drive of the fifth embodiment to provide the “driving member comprising a third thread” of claim 21.” *Id.*

Petitioner also explains its proposed modification of driver tube 85 and member 40 as follows:

While driver tube 85 (the driver) does not show internal threading in the [Figures] 15–17 embodiment, Steinfeldt-Jensen suggests an alternative embodiment in which (1) driver tube 85 does have such threading and rotates relative to piston rod 6 during injection to drive the piston rod through member 40 and (2) member 40 operates as a non-threaded piston-rod guide, preventing rotation of piston rod 6 relative to the housing but allowing axial displacement. In such an embodiment, a [person of ordinary skill in the art] would have considered driver tube 85 to meet all limitation of the recited “driving member” and member 40 to meet all limitations of the recited “piston rod holder.” *See* EX1011 ¶¶ 620–621.

Pet. 53.

For purposes of this portion of our analysis, Petitioner shows, and Patent Owner does not dispute, that driver tube 85, as modified by Petitioner, corresponds to the recited “driving member comprising a third thread.” We are persuaded that Petitioner shows by a preponderance of the evidence that Steinfeldt-Jensen suggests this limitation based on the reasons and evidence identified in the portions of the Petition cited in the preceding three paragraphs, which we adopt as our own findings. We address below Petitioner’s reasons in support of its proposed modification and Patent Owner’s arguments related to Petitioner’s reasoning (after addressing the subject matter of each remaining limitation of claim 21, including a “piston rod holder”).

- e) a sleeve that is (i) disposed between the dose indicator and the driving member and (ii) releasably connected to the dose indicator;*

Petitioner establishes, and Patent Owner does not dispute, that Steinfeldt-Jensen teaches bushing 82 corresponding to the recited “sleeve.” Pet. 34–36. Petitioner explains that “bushing 82 is a tubular structure that is disposed between dose indicator 80 and drive member 85.” *Id.* (referencing Ex. 1014, 11:26–27, 12:4–13; Figs. 15–17; Ex. 1011 ¶ 628). Further, Petitioner explains that bushing 82 with flange 83 is releasably connected to a dose indicator, scale drum 80, because flange 83 has rosette of teeth 93 that are configured to releasably engage corresponding teeth on dose-setting button 81, and dose-setting button 81 is integrally formed with scale drum 80. *Id.* (referencing Ex. 1014, 11:22–25; Ex. 1011 ¶ 629).

We are persuaded that Petitioner shows by a preponderance of the evidence that Steinfeldt-Jensen teaches this limitation based on the reasons and evidence identified in the portions of the Petition cited in the preceding paragraph, which we adopt as our own findings.

- f) a piston rod comprising either an internal or an external fourth thread that is engaged with the third thread*

Petitioner shows, and Patent Owner does not dispute, that Steinfeldt-Jensen teaches piston rod 6 having an external thread 7 corresponding to the recited “piston rod.” Pet. 37–38 (citing Ex. 1014, 5:55–58). Petitioner also explains that when driver tube 85 is modified as proposed, piston rod 6 with external threading 7 would engage internal threads, i.e., the recited “third thread,” of modified driver tube 85. *Id.* at 38. Patent Owner does not present any additional arguments regarding the “piston rod” of claim 21 beyond the arguments discussed below concerning Petitioner’s proposed modification of driver tube 85. *See* PO Resp. 21–41. For purposes of this

portion of our analysis, Petitioner shows, and Patent Owner does not dispute, that piston rod 6 corresponds to the recited “piston rod” and would engage driver tube 85, as modified by Petitioner.

We are persuaded that Petitioner shows by a preponderance of the evidence that Steinfeldt-Jensen teaches this limitation based on the reasons and evidence identified in the portions of the Petition cited in the preceding paragraph, which we adopt as our own findings.

- g) a piston rod holder that is rotatably fixed relative to the housing and configured to (i) prevent the piston rod from rotating during dose setting and (ii) permit the piston rod to traverse axially towards the distal end during dose dispensing*

Petitioner shows that Steinfeldt-Jensen teaches member 40 rotatably fixed relative to housing 1, corresponding to the recited “piston rod holder.” Pet. 38–43 (citing Ex. 1014, 8:35–42 (longitudinal recesses 43 of member 40 with internal ribs of housing 1 “lock the member 40 against rotation relative to the housing”); Ex. 1011 ¶ 633). Although Petitioner proposes modifying the piston rod drive of Steinfeldt-Jensen “so that the internal threads of the piston rod drive are located on driver tube 85 instead of on member 40 and so that member 40 (instead of driver tube 85) mates with the not circular cross-section of the piston rod,” Petitioner shows that modified member 40, after modification to operate as a “non-threaded piston-rod guide,” would still be rotatably fixed relative to the housing. Pet. 42, 53 (citing Ex. 1011 ¶¶ 636–638).

Petitioner also shows that “[b]y virtue of being rotatably fixed relative to the housing, member 40 is configured to prevent the piston rod from rotating relative to the housing during dose setting via the interaction of its pawl wheel teeth with the pawl wheel of driver tube 85.” *Id.* at 41–42 (citing Ex. 1014, 8:48–53, 11:6–19, 11:52–62; Ex. 1011 ¶¶ 634–635).

Petitioner further shows member 40, with or without Petitioner's proposed modification, permits piston rod 6 to "traverse axially towards the distal end during dose dispensing," as recited. *Id.* at 42–43 (citing Ex. 1014, 11:11–15, 12:4–12; Ex. 1011 ¶¶ 638–639).

Patent Owner does not present any additional arguments regarding the "piston rod holder" of claim 21 beyond the arguments discussed below concerning Petitioner's proposed modification of driver tube 85. *See* PO Resp. 27–43. For purposes of this portion of our analysis, Petitioner shows, and Patent Owner does not dispute, that member 40, as modified by Petitioner, corresponds to the recited "piston rod holder." We are persuaded that Petitioner shows by a preponderance of the evidence that Steinfeldt-Jensen suggests this limitation based on the reasons and evidence identified in the portions of the Petition cited in the preceding two paragraphs, which we adopt as our own findings.

h) wherein: the housing is disposed at an outermost position of the drug delivery device;

Petitioner shows, and Patent Owner does not dispute, that Steinfeldt-Jensen teaches that housing 1 is disposed at an outermost position of Steinfeldt-Jensen's syringe. Pet. 43–44 (citing Ex. 1014, 5:38–44, Figs. 15–17; Ex. 1011 ¶¶ 640–641). We are persuaded that Petitioner shows by a preponderance of the evidence that Steinfeldt-Jensen teaches this limitation based on the reasons and evidence identified in the portions of the Petition cited in the preceding sentence, which we adopt as our own findings.

- i) the dose indicator is disposed between the housing and the sleeve and is configured to (i) rotate and traverse axially away from the dose dispensing end during dose setting and (ii) rotate and traverse axially towards the dose dispensing end during dose dispensing;*

Petitioner shows, and Patent Owner does not dispute, that Steinfeldt-Jensen teaches scale drum 80, a “dose indicator,” is disposed between housing 1, a “housing,” and bushing 82, a “sleeve” and is configured to “rotate and traverse axially away from the dose dispensing end during dose setting and (ii) rotate and traverse axially towards the dose dispensing end during dose dispensing,” as recited. Pet. 44–45 (citing Ex. 1014, 11:20–28, 11:52–54, 12:4–9, Figs. 15–17; Ex. 1011 ¶¶ 642, 644). We are persuaded that Petitioner shows by a preponderance of the evidence that Steinfeldt-Jensen teaches this limitation based on the reasons and evidence identified in the portions of the Petition cited in the preceding sentence, which we adopt as our own findings.

- j) the driving member is configured to rotate relative to the piston rod;*

Petitioner relies on a modified driver tube 85 as the recited “driving member.” Petitioner explains that, prior to the proposed modification, Steinfeldt-Jensen teaches that member 40 rotates relative to piston rod 6, “because the piston rod 6 is coupled to the driver tube 85 in such a way that “rotation is transmitted.” Pet. 46 (citing Ex. 1014, 11:15–19). Petitioner proposes modifying driver tube 85 whereby “the internal threads of the piston rod drive are located on driver tube 85 instead of member 40.” As a result of the modification, driver tube 85 rotates relative to piston rod 6 during dose dispensing because “member 40 (instead of driver tube 85) mates with the not circular cross-section of the piston rod.” Pet. 46.

Patent Owner does not present any additional arguments regarding this limitation of claim 21 beyond the arguments discussed below concerning Petitioner's proposed modification of driver tube 85. *See* PO Resp. 21–41. For purposes of this portion of our analysis, Petitioner shows, and Patent Owner does not dispute, that driver tube 85, as modified by Petitioner, is “configured to rotate relative to the piston rod.” We are persuaded that Petitioner shows by a preponderance of the evidence that Steinfeldt-Jensen teaches and suggests this limitation based on the reasons and evidence identified in the portions of the Petition cited in the preceding paragraph, which we adopt as our own findings.

k) the sleeve is rotatably fixed relative to the driving member and configured to traverse axially with the dose indicator; and

Petitioner shows, and Patent Owner does not dispute, that Steinfeldt-Jensen teaches that bushing 82, a “sleeve,” is “kept non-rotated,” i.e., rotatably fixed, relative to driver tube 85, a “driving member,” “due to its coupling to the driver tube.” Pet. 47 (quoting Ex. 1014, 11:55–56). Petitioner explains that bushing 82 and driver tube 85 are coupled so that they rotate together, but that longitudinal displacement is not transmitted between the two components. *Id.* at 48 (citing Ex. 1014, 11:26–33, 11:55–56; Ex. 1011 ¶ 649). Petitioner further shows that “[b]ushing 82 is also configured to traverse axially with the dose indicator” and “with scale drum 80 during dose dispensing.” *Id.* at 47–50 (citing Ex. 1014, 12:4–9, Figs. 15–17; Ex. 1011 ¶ 652). Mr. Leinsing explains that bushing 82 “is configured to traverse axially towards the dose dispensing end with scale drum 80 during dose dispensing,” because, as shown in Figures 15 and 16, “injection button 88 pushes scale drum 80 back into the housing via bushing 82.” Ex. 1011 ¶ 652.

We are persuaded that Petitioner shows by a preponderance of the evidence that Steinfeldt-Jensen teaches this limitation based on the reasons and evidence identified in the portions of the Petition cited in the preceding paragraph, which we adopt as our own findings.

- l) *the piston rod and the driving member are configured to rotate relative to one another during dose dispensing; and*

This limitation is substantially similar to the limitation addressed above: “the driving member is configured to rotate relative to the piston rod.” Petitioner, again, relies on a modified driver tube 85 as the recited “driving member.” Pet. 50–51. Petitioner explains that, prior to the proposed modification, Steinfeldt-Jensen teaches that member 40 rotates relative to piston rod 6 during dose dispensing, “because the piston rod 6 is coupled to the driver tube 85 in such a way that “rotation is transmitted.” Pet. 51 (citing Ex. 1014, 8:48–53, 11:6–19, 11:52–62, 12:4–12; Ex. 1011 ¶ 654). Petitioner proposes modifying driver tube 85 whereby “the internal threads of the piston rod drive are located on driver tube 85 instead of member 40.” *Id.* As a result of the modification, driver tube 85 rotates relative to piston rod 6 during dose dispensing because “member 40 (instead of driver tube 85) mates with the not circular cross-section of the piston rod.” *Id.*

Patent Owner does not present any additional arguments regarding this limitation of claim 21 beyond the arguments discussed below concerning Petitioner’s proposed modification of driver tube 85. *See* PO Resp. 21–41. For purposes of this portion of our analysis, Petitioner shows, and Patent Owner does not dispute, that piston rod 6 and member 40, as modified by Petitioner, are “configured to rotate relative to one another during dose dispensing.” We are persuaded that Petitioner shows by a

preponderance of the evidence that Steinfeldt-Jensen teaches and suggests this limitation based on the reasons and evidence identified in the portions of the Petition cited in the preceding paragraph, which we adopt as our own findings.

m) the piston rod is configured to traverse axially towards the dose dispensing end during dose dispensing.

Petitioner shows, and Patent Owner does not dispute, that Steinfeldt-Jensen teaches piston rod 6 is configured to traverse axially towards the dose-dispensing end during dose dispensing (with or without Petitioner's proposed modification of driver tube 85). Pet. 52–53 (citing Ex. 1011 ¶¶ 656–657; Ex. 1014, 11:11–19, 12:4–12). Petitioner explains that “[s]wapping the location of the threads and the non-circular cross-section as between driver tube 85 and member 40 still would result in piston rod 6 configured to traverse axially towards the dose dispensing end during dose dispensing.” Pet. 53.

Patent Owner does not present any additional arguments regarding this limitation of claim 21 beyond the arguments discussed below concerning Petitioner's proposed modification of driver tube 85. See PO Resp. 21–41. We are persuaded that Petitioner shows by a preponderance of the evidence that Steinfeldt-Jensen teaches this limitation based on the reasons and evidence identified in the portions of the Petition cited in the preceding paragraph, which we adopt as our own findings.

2. Reasons for the Proposed Modification of the Piston Rod Drive of Steinfeldt-Jensen

Petitioner relies on Steinfeldt-Jensen as expressly providing the rationale for the proposed modification. Pet. 53–56. Petitioner contends that Steinfeldt-Jensen suggests an alternative embodiment in which driver

tube 85 has internal threading “and rotates relative to piston rod 6 during injection to drive the piston rod through member 40,” and “member 40 operates as a non-threaded piston-rod guide, preventing rotation of piston rod 6 relative to the housing but allowing axial displacement.” Pet. 53.

As explained by Mr. Leinsing, Steinfeldt-Jensen teaches two approaches for driving the piston rod: the “fixed-nut approach,” whereby “rotation of the scale drum can *rotate the piston rod* relative to the nut member,” and the “rotating-nut approach,” whereby “rotation of the scale drum can *rotate the nut member* relative to the piston rod.” Ex. 1011 ¶ 622–623 (emphases added). *Id.* The fifth embodiment applies the “fixed-nut” approach, where “driver tube 85 is rotationally coupled to piston rod 6 and rotation of scale drum 80 during injection rotates driver tube 85 and piston rod 6 relative to member 40, which is essentially a fixed ‘nut member’.” Ex. 1011 ¶ 623. Petitioner proposes modifying driver tube 85 and member 40 to utilize the “rotating-nut” approach in place of the “fixed-nut” approach. In this regard, Mr. Leinsing states, and we agree, that Steinfeldt-Jensen teaches the alternative “rotating-nut” approach “in general terms” by describing a “‘piston rod guide’ relative to which the piston rod is “axially displaceable but not rotatable,”” and a “‘nut member’ that is ‘rotatable but not axially displaceable in the housing and which has an inner thread mating the thread of the piston rod.” *Id.* ¶ 622 (quoting Ex. 1014, 2:40–53); *see also* Pet. 53–54. Specifically, Steinfeldt-Jensen states, in relevant part, the following with regard to obtaining a syringe with advantageous features:

This is obtained by []injection syringes for apportioning set doses of a medicine from a cartridge containing an amount of medicine sufficient for the preparation of a number of therapeutic doses, comprising
a housing

- a piston rod having a not circular cross-section and an outer thread
- a piston rod drive comprising two elements
 - a) a piston rod guide in relation to which the piston rod is axially displaceable but not rotatable, and
 - b) a nut member which is rotatable but not axially displaceable in the housing and which has an inner thread mating the thread of the piston rod to form a self locking thread connection.

Ex. 1014, 2:40–53 (the “General Disclosure”). Thus, Petitioner shows that its proposed modification of driver tube 85 to include internal threads and modification of member 40 to operate as a piston rod guide is suggested by Steinfeldt-Jensen. In particular, as explained by Mr. Leinsing, “Steenfeldt-Jensen teaches that embodiments using the fixed-nut approach can be implemented by the rotating-nut approach.” Ex. 1011 ¶ 623. In support of his opinion, Mr. Leinsing identifies the following Steinfeldt-Jensen disclosures:

- “When the injection button is pressed the movement of this button is transformed into a rotation of the piston rod (or the nut member) relative to the nut member (or the piston rod). When the button is pressed hard enough the initial reluctan[ce] is overcome so that the two elements, the piston rod and the nut member, are rotated relative to each other.” Ex. 1014, 3:15–20 (the “Rotation Disclosure”).
- “The thread connection by which the injection button is screwed out from the housing by setting a dose may be the thread connection between the dose scale drum and the housing. In this case the dose scale drum must be coupled to a driver rotating the piston rod (or the nut member) relative to the nut member (or the piston rod) when the injection button is pressed.” *Id.* at 3:41–47 (the “Driver Disclosure”).

- “In the shown embodiment the end wall 4 with its threaded bore forms a nut member relative to which the piston rod is rotated by the piston rod guide 14 and the driver tube 26. Embodiments may be imagined wherein the piston rod guide is provided in the wall 4 and a nut element is rotated by the driver tube and such embodiment will not be beyond the scope of the invention.” Ex. 1014, 7:41–47 (the “Rotating-Nut Disclosure”).

Ex. 1011 ¶¶ 622–623. The Rotation Disclosure and the Driver Disclosure appear in the Specification of Steinfeldt-Jensen in the general description of the invention, and the Rotating-Nut Disclosure appears in the Specification in the description of the first embodiment corresponding to Figures 1 to 5. *See* Ex. 1014, 5:33–7:47. Petitioner reasons that a person of ordinary skill in the art “would have interpreted Steinfeldt-Jensen as suggesting that driver tube 85 could be implemented with internal threading (i.e. as a rotating-nut element),” for engaging the external threading of piston rod 6, “while member 40 could be implemented as a fixed piston rod guide (i.e. preventing rotation of piston rod 6 relative to the housing)” to include a non-circular cross-section for preventing rotation of piston rod 6 relative to the housing while permitting axial displacement. *Id.* (citing Ex. 1011 ¶ 624). We agree with Petitioner that the four disclosures identified above show that Steinfeldt-Jensen suggests that fixed-nut and rotating-nut approaches are interchangeable and expressly contemplated alternative configurations of the piston rod drive. *See* Pet. 55.

Further, Petitioner shows, as supported by Mr. Leinsing, that a person of ordinary skill in the art would have had a reasonable expectation of success applying the proposed modifications to Steinfeldt-Jensen, because: (1) such a person “would have been familiar with the structure and operation of drive nuts that rotate to push a non-rotating piston rod forward,” and (2) such a person would have “expected such

modifications to involve the use of familiar elements operating in a predictable manner,” because Steinfeldt–Jensen taught “the interchangeability of fixed-nut and rotating-nut embodiments.” Pet. 55 (citing Ex. 1011 ¶ 625). Petitioner also shows that a person of ordinary skill in the art would have recognized that the proposed modifications would not have changed the principle of operation of the device, because it would have allowed “all other aspects of the device” to operate the same. Pet. 55–56 (citing Ex. 1011 ¶ 625). Finally, Petitioner shows that the design and operation of the modified device “would have been routine and predictable,” and “would have involved the use of well-known, familiar elements performing their same, predictable functions.” *Id.* (citing Ex. 1011 ¶ 626).

We find Petitioner’s arguments and evidence persuasively establish that Petitioner’s proposed modifications to Steinfeldt-Jensen’s fifth embodiment apply known elements suggested by Steinfeldt-Jensen in a routine and predictable manner, that a person of ordinary skill in the art would have reasonably expected the modified parts to perform the same function as before, and thus, one of ordinary skill in the art would have had a reasonable expectation of success in making Petitioner’s proposed modifications of. *Id.* (citing Ex. 1011 ¶¶ 625, 626). Patent Owner’s evidence and arguments to the contrary, which we address in detail below, do not persuasively refute Petitioner’s showing in this regard.

In response to Petitioner, Patent Owner argues that there is no disclosure or suggestion in Steinfeldt-Jensen of an internally threaded driver tube, that the Rotating-Nut Disclosure applies only to the first embodiment (not to the fifth embodiment), and that a person of ordinary skill would have been dissuaded from making Petitioner’s proposed modification because it would have resulted in an inferior pen and because of potential failures in

the flexible arms of the alternative driver. PO Resp. 21–41; PO Sur-reply 1–16. We address each of these arguments below and conclude on the whole record that Petitioner shows a legally sufficient rationale for the proposed modification of the fifth embodiment of Steinfeldt-Jensen.

a) Petitioner Shows that a Person of Ordinary Skill in the Art Would Have Understood Steinfeldt-Jensen Suggests an Internally Threaded Driver Tube

For the reasons provided above, Petitioner shows that Steinfeldt-Jensen suggests an internally threaded driver tube. Patent Owner argues that Petitioner fails to show how Steinfeldt-Jensen “discloses or suggests an internally threaded driver tube,” because all of the passages Petitioner relies on disclose “an internally threaded ‘nut member’ or ‘nut element’, which is rotated by a driver tube,” such that “the driver tube itself is not threaded.” PO Resp. 21–23 (citing Ex. 1014, 2:40–53 (the General Disclosure discussing a threaded “nut element”), 3:15–20, 3:41–47 (the Rotation Disclosure and the Driver Disclosure discussing a “nut member”); 7:41–47 (the Rotating-Nut Disclosure discussing a “nut member”). According to Patent Owner, these passages “teach an internally threaded nut member and a piston rod with relative movement between the two components, [b]ut the nut member is not the driver tube, and Steinfeldt-Jensen makes clear throughout its disclosure that the nut member and the driver tube are different components.” PO Resp. 23; *see also* Ex. 2107 ¶ 215–220 (supporting Patent Owner’s contentions). In support, Dr. Slocum explains, for example, that in the third embodiment taught by Steinfeldt-Jensen, the nut member 48 is distinct from driver tube 45. Ex. 2107 ¶ 221. Thus, Patent Owner asserts that the teachings from Steinfeldt-Jensen that Petitioner relies on “do not support the modification suggested by Petitioner.” PO Resp. 23.

In reply, Petitioner shows that Steinfeldt-Jensen “makes clear that a driver with a nut member *is* an internally-threaded driver.” Pet. Reply 3.⁹ Petitioner supports its argument by drawing a parallel to Steinfeldt-Jensen’s teachings with regard to the driver and the piston rod guide. According to Petitioner, Steinfeldt-Jensen teaches a driver rotating a piston rod guide, but further explains that the piston rod guide is not a separate component from the driver. *Id.* (citing Ex. 1095 ¶ 65; Ex. 1014, 6:35–36 (driver tube 26 is “integral with the piston rod guide”), 11:15–19 (equating the piston rod guide to the rectangular bore of the driver tube). In this regard, Mr. Leinsing explains that a “person of ordinary skill, understanding that a driver tube with a piston rod guide is equivalent to a driver tube with a rectangular bore, would have also understood that a driver tube with a nut member is equivalent to a driver tube with an internally-threaded bore.” Ex. 1095 ¶ 65.

Mr. Leinsing supports his opinion by explaining that Steinfeldt-Jensen describes a “nut member” in a “fixed-nut” embodiment as being formed by “end wall 4 with its threaded bore.” *Id.* (quoting Ex. 1014, 7:41–43). According to Mr. Leinsing, “the person of ordinary skill would have understood that, when Steinfeldt-Jensen refers to a ‘nut member’ or ‘nut elements,’ it is to an internally threaded component for engaging the piston rod (e.g., end wall 4), and that “a driver tube with an internally threaded bore would similarly operate as a ‘nut member.’” *Id.*

⁹ In its Reply, Petitioner also argues that another reference (Ex. 1016) supports its contentions, because Petitioner’s proposed modifications are consistent with the approach applied in the other reference. Pet. Reply 18–19. Patent Owner argues that Petitioner’s argument is improper because it was not raised in the Petition. PO Sur-reply 14–15. We need not resolve the issue raised by Patent Owner, because our Decision does not rely on the disputed arguments presented by Petitioner.

Patent Owner argues in sur-reply: (1) that “the claims specifically require *a threaded driver tube*, not a nut member rotated by a driver tube,” and that “the distinction matters;” (2) that “nowhere does Steinfeldt-Jensen teach an integrally formed nut member,” and instead “universally describes its nut member as a separate component;” and (3) that “the leap Petitioner uses to demonstrate its integrally formed nut member is predicated on a misreading” of the Driver Disclosure. PO Sur-reply 11–14. In support, Patent Owner shows, and Petitioner does not dispute, that “in the first, third, fourth, and fifth embodiments” of Steinfeldt-Jensen the nut member is separate and distinct from the driver tube. *Id.* at 11–12 (citing Ex. 1014, Figs. 2, 12, 14, 16). Patent Owner also shows that the Driver Disclosure “does not mention” an “integrally formed nut member,” because those words plainly don’t appear in that disclosure. *Id.* at 12. Patent Owner further argues that “Steenfeldt-Jensen does not equate the piston rod driver with a nut member,” and “in no way suggests the nut member may be integrally formed with the driver tube.” *Id.* at 13–15. With regard to the Rotating-Nut Disclosure, Patent Owner argues that it does not suggest a nut member integrally formed with a driver tube, because it states “end wall 4 with its threaded bore forms a nut member” and “[e]nd wall 4 is not the driver tube.” *Id.* at 14 (citing Ex. 1014, 7:41–43).

Patent Owner’s arguments are not persuasive. Although Patent Owner argues in various ways that Steinfeldt-Jensen contains no express teaching of a driver tube with internal threading, that fact was never in dispute, and the understanding of a person of ordinary skill in the art would not have been limited to only Steinfeldt-Jensen’s express teachings. *See* PO Sur-reply 10–14 (citing Pet. Reply 2–3; Ex. 1014, 3:41–47, 7:41–43, Figs. 2, 12, 14, 16). Patent Owner does not discredit Mr. Leinsing’s explanation that

there were two well-known approaches for driving the piston rod involving either a “fixed-nut approach” or a “rotating-nut approach,” and that Steinfeldt–Jensen taught the interchangeability of the two approaches. Patent Owner does not otherwise adequately refute Petitioner’s showing, supported by Mr. Leinsing, that the General Disclosure, the Rotation Disclosure, the Driver Disclosure, and the Rotating-Nut Disclosure collectively, and in context, would have suggested to a person of ordinary skill in the art a driver tube with an integral nut element, i.e., driver tube 85 modified with internal threading, as proposed by Petitioner. *See* Pet. Reply 2–3 (citing Pet. 53–56; PO Resp. 21; Ex. 1014, 3:41–47, 6:35–36, 11:15–19; Ex. 1095 ¶¶ 63–65; Ex. 2107 ¶¶ 30, 215–222).

b) Petitioner Shows that the Rotating-Nut Disclosure of Steinfeldt-Jensen is Not Limited to the First Embodiment and Applies to the Fifth Embodiment

For the reasons provided above, Petitioner shows that Steinfeldt-Jensen suggests an internally threaded driver tube in light of the Rotating-Nut Disclosure, not alone, but in combination with the General Disclosure, the Rotation Disclosure, and the Driver Disclosure. Patent Owner directs a number of arguments towards the Rotating-Nut Disclosure, in isolation. Specifically, Patent Owner argues that the Rotating-Nut Disclosure does not suggest Petitioner’s proposed modification of driver tube 85 because a person of ordinary skill in art would have understood that the disclosure “is not applicable to the fifth embodiment” of Steinfeldt-Jensen.” PO Resp. 24 (citing Ex. 2107 ¶¶ 223–226).

Petitioner reasons that one of ordinary skill in the art would have known that the Rotating-Nut Disclosure would also apply to the fifth embodiment and that such a general suggestion does not have to be repeated

because Steinfeldt-Jensen teaches alternative driver mechanisms before describing other embodiments. Pet. Reply 3–9 (citing Ex. 1014, 2:40–53, 3:10–20, 3:41–47; Ex. 1095 ¶¶ 66–69). Even though the Rotating-Nut Disclosure applies expressly to the first embodiment, we find that Petitioner shows that this disclosure would have suggested, to one of ordinary skill in the art, to consider a similar alternative for other embodiments, such as Steinfeldt-Jensen’s fifth embodiment even though the same disclosure is not repeated after each discussion of each embodiment. *Id.* (responding to PO Resp. 24–26). We address each of Patent Owner’s arguments below.

First, Patent Owner argues that the “shown embodiment” referred to in the Rotating-Nut Disclosure is the first embodiment (corresponding to Figures 1–5 of Steinfeldt-Jensen) and that the description of the fifth embodiment “does not include a similar passage.” PO Resp. 24. Patent Owner also argues that Steinfeldt-Jensen’s provisional application included the Rotating-Nut Disclosure and first embodiment, but not the fifth embodiment. According to Patent Owner, when the fifth embodiment was added, “similar language was not included to cover the fifth embodiment . . . indicating that the [Rotating-Nut Disclosure] is not applicable to the fifth embodiment.” PO Resp. 24–25 (citing Ex. 1014, 5:33–7:47, 11:6–12:16; Ex. 2127, 11:2–5).

While each of Patent Owner’s factual assertions appears to be correct, they do not lead to Patent Owner’s conclusion that the Rotating-Nut Disclosure would not have suggested to one of ordinary skill in the art that it could not be applied to the fifth embodiment. Petitioner shows that Steinfeldt-Jensen discusses an alternative rotating-nut drive mechanism outside of the first embodiment, for example, the General Disclosure, in a consistent manner with the Rotating-Nut Disclosure, thereby suggesting to a

person of ordinary skill in the art that the Rotating-Nut Disclosure is applicable to more than the first embodiment in which it arises. *See* Pet. Reply 4–5 (citing Ex. 1095 ¶ 66). In sum, even though the Rotating-Nut Disclosure applies directly to the first embodiment, we agree with Petitioner that this express teaching would have, at least, suggested to one of ordinary skill in the art to consider a similar alternative for the fifth embodiment as well, even though the same statement is not repeated after the discussion of the fifth embodiment. *See* Pet. 61–62; Pet. Reply 9–11.

Second, Patent Owner argues that a person of ordinary skill in the art would have understood that the Rotating-Nut Disclosure was not a “general teaching,” because if it were applied to Steinfeldt-Jensen’s second embodiment the result would have been a non-functioning pen injector. PO Resp. 31 (citing Ex. 2107 ¶ 226). Again, we find no rationale for Patent Owner’s assertion that, because a general teaching may not apply to one embodiment, a person of ordinary skill in the art would have understood it does not apply to any of the other embodiments. More specifically, we find persuasive Petitioner’s explanation that the drive mechanism taught in the second embodiment of Steinfeldt-Jensen is not analogous to the first or fifth embodiments, because the second embodiment *does not have a driver tube*. *See* Pet. Reply 7 (citing Ex. 1014, 7:51–54 (“Different from the embodiment in FIG. 1–5 is the fact that...the driver tube 26 is omitted.”), Figs. 6–10); *see also* Ex. 1095 ¶ 70 (explaining that a person of ordinary skill in the art would have “appreciated that the drive mechanism of the second embodiment operates in a fundamentally different way” from the first and fifth embodiments).

Third, Patent Owner argues that the Rotating-Nut Disclosure does not suggest Petitioner’s proposed modification, but instead “teaches putting a

piston rod guide in end wall 4 of ampoule holder 2 (of the first embodiment), and having driver tube 26 (of the first embodiment) rotate a nut element.”

PO Resp. 26 (citing Ex. 2107 ¶ 215). Contrary to Patent Owner’s argument, we find persuasive Petitioner’s showing that because the first and fifth embodiments have analogous features, the Rotating-Nut Disclosure would have suggested to a person of ordinary skill in the art that it could apply to the fifth embodiment. Petitioner explains in detail that the first and fifth embodiments of Steinfeldt-Jensen utilize “analogous drive mechanisms” and that a person of ordinary skill in the art would have recognized that Petitioner’s proposed modification to the driver tube and wall 4 “would have been the same and had the same impact” for both embodiments. Pet.

Reply 5–7 (citing Ex. 1014, 5:55–61, 6:35–37, 7:3–8, 7:17–35, 7:41–43, 11:15–21, 11:52–55, 12:4–13, FIGS. 2, 3, 16-17; Ex. 1095 ¶¶ 68, 69).

Petitioner further shows in this regard that Dr. Slocum agreed that the driver tubes in the first and fifth embodiments have “the same engagement method” with the piston rod and apply torque in the same way. Ex. 1054, 306:23–307:19; *see also id.*, 342:3–343:18 (agreeing that transmission of force in the first and fifth embodiments was “the same fundamental type of thing” and that “driver tube 85 . . . essentially is the same as 26”).

Mr. Leinsing similarly explained that “a person of ordinary skill would have understood the drive mechanisms of the first and fifth embodiments as structurally and functionally equivalent for injection purposes.”

Ex. 1095 ¶ 70.

Patent Owner argues in its Sur-reply that Petitioner “concedes” the Rotating-Nut Disclosure “is not a blanket statement” covering every embodiment, that Mr. Leinsing “acknowledges that there are differences between the first and fifth embodiments,” and that Patent Owner “had shown

that the first and the fifth embodiments are not analogous.” Sur-reply 4 (citing Ex. 1095 ¶ 68; PO Resp. 19–21). As explained above, merely because the Rotating-Nut Disclosure does not apply to the second embodiment (i.e., because that embodiment does not have a driver tube), does not detract from Petitioner’s position and our finding that it suggests applicability to the fifth embodiment (which, like the first embodiment, has a driver tube). Further, given that the first and fifth embodiments are, in fact, different embodiments, Patent Owner’s assertion that there are differences between the two does not detract from our finding. Further, given that the first and fifth embodiments are, in fact, different embodiments, Patent Owner’s assertion that there are differences between the two does not detract from our finding. Likewise, in the portion of Patent Owner’s Response cited, Patent Owner describes the first and fifth embodiments as “separate and distinct,” but does not state that they are “not analogous.” PO Resp. 19–21. Indeed, one would expect two embodiments to be separate and distinct. The entire explanation of this distinction provided by Patent Owner consists of the following:

In particular, Steinfeldt-Jensen’s first embodiment comprises components that are not part of the fifth embodiment and vice versa. The first embodiment includes an ampoule holder 2 [] that is rotatable with respect to the housing 1 [] and includes an end wall 4 with a threaded opening 5 that mates with the threads on piston rod 6 []. The first embodiment also identifies a piston rod guide 14 [] and a driver tube 26 []. The fifth embodiment, however, does not have an ampoule holder 2 with a threaded end wall 4. Instead, the fifth embodiment includes member 40 [] with a threaded end wall 4.

Id. at 20. Patent Owner fails to show that the differences Patent Owner identifies have any material impact to the modifications proposed by

Petitioner, much less that those differences refute Petitioner's showing that the embodiments are analogous, as explained above

We agree with Petitioner that (1) the various embodiments of Steinfeldt-Jensen have either analogous or the same components, and (2) Steinfeldt-Jensen does not repeat descriptions for those components in the discussion of each latter embodiment, including wall 4. *See* Pet. Reply 5–7 (citing Ex. 1095 ¶¶ 66–69). For example, the first embodiment includes “wall 4 having a central bore with an internal thread 5” and “piston rod 6 having an external thread 7 mating the thread 5 of said bore” (Ex. 1014, 5:56–58) and the discussion of the fifth embodiment states that “the thread of the piston rod and the thread in the end wall of the housing is so designed that an anticlockwise rotation of the piston will screw the piston rod through said end wall” (*id.* at 11:11–14). *See also id.* at Fig. 2 (showing, for the first embodiment, externally threaded piston rod 6 engaging internally threaded wall 4), Figs. 15–16 (showing, for the fifth embodiment, externally threaded piston rod 6 engaging internally threaded wall 4). In other words, Steinfeldt-Jensen need not expressly identify wall 4 in its description of the fifth embodiment, because wall 4 is sufficiently identified in the first embodiment and wall 4 is illustrated in Figures 15 and 16 with regard to the fifth embodiment. *See* Ex. 1014, 5:55–58, 11:11–14, Figs. 2, 15, 16.

We find that one of ordinary skill in the art would have understood that Steinfeldt-Jensen employed this method of description and would have applied the Rotating-Nut Disclosure to embodiments with the same or analogous components, such as the fifth embodiment, because the Rotating-Nut Disclosure relates to, at least, wall 4, which is included in both the first and fifth embodiments. Ex. 1011 ¶ 277; Ex. 1095 ¶ 69. We also find that the

first and fifth embodiments have substantially similar arrangements of piston rods, piston rod guides, and nut members. *Compare id.* at Fig. 3, *with id.* at Fig. 17; *see also* Ex. 1054, 306:23–308:9 (Dr. Slocum testifying that driver tubes and piston rods shown in Figures 3 and 17 work similarly), 342:3–343:19 (Dr. Slocum testifying that driver tubes of the first and fifth embodiments work similarly). Additionally, we find that the fact that Steinfeldt-Jensen does not repeat the description of the piston rod guide or nut element, also discussed in the Rotating-Nut Disclosure, means that these components are not so different from the first embodiment that further description of those components was warranted in the fifth embodiments.

In sum, for the reasons provided above, Petitioner persuades us that one of ordinary skill in the art, reading from the Rotating-Nut Disclosure that an alternative arrangement can include a “piston rod guide [that] is provided in the wall 4 and a nut element [that] is rotated by the driver tube,” “would have reason to modify (1) driver tube 85 to include an internal threading for engaging the piston rod’s external threading, and (2) member 40 to include a non-circular cross-section for axially guiding the piston rod” in Steinfeldt-Jensen’s fifth embodiment. Pet. 61; Ex. 1011 ¶ 277; Ex. 1095 ¶ 69.

c) A Person of Ordinary Skill in the Art Would Not Have Been Dissuaded by Inferior Results from Applying Petitioner’s Proposed Modifications to Steinfeldt-Jensen

Patent Owner argues that a person of ordinary skill in the art would not have been motivated to modify Steinfeldt-Jensen to move “the threads on member 40 to the driver tube,” and to move “the non-circular slot on the driver tube to member 40,” because it would introduce higher friction and result in an inferior injection pen “with higher injection force,” a

“benchmark for these products.” PO Resp. 26–28 (citing Ex. 1004, 4:7–9; Ex. 1015 ¶¶ 4–6; Ex. 2107 ¶¶ 37–39, 44–45, 54, 56–57, 232–238; Ex. 2163, 80:17–81:5). Patent Owner’s argument is supported by Dr. Slocum, who “created analytical models presented in the form of a spreadsheet” and explains a physical model (the “Collar Friction Model”) that “directly compares Steinfeldt-Jensen’s fifth embodiment with Petitioner’s proposed modification to the fifth embodiment.” *Id.* at 28 (citing Ex. 2107 ¶¶ 245–255; Exs. 2211, 2215–2217).

According to Patent Owner, the analytical model used by Dr. Slocum shows that “Petitioner’s proposed modification increases the amount of force required from the user to inject a dose by 51%.” *Id.* at 29 (citing Ex. 2107 ¶¶ 242–244, App. A). Patent Owner also argues that, as explained by Dr. Slocum, the Collar Friction Model shows that “rotating the Collar with the Threaded Insert (Petitioner’s proposed modification) is more difficult than rotating the Collar with the Guide (Steenfeldt-Jensen’s fifth embodiment).” *Id.* at 29–34 (citing Ex. 2107 ¶¶ 245–255; Exs. 2215–2217); *see also id.* at 33–34 (stating that the modified device “requires 50% more force on average to advance the piston rod” than the unmodified device). Patent Owner also provides a detailed explanation for why Petitioner’s modification results in higher friction. *Id.* at 34–37 (citing Ex. 2107 ¶¶ 233–238, 242–244; Ex. 1014, 12:10–13, Fig. 16; Ex. 2152). Thus, Patent Owner asserts that, “contrary to the critical design objectives in this art,” “[m]odifying the fifth embodiment as Petitioner proposes *increases friction* and impairs the device.” *Id.* at 37 (citing Ex. 1004, 1:36–40; Ex. 1015 ¶¶ 4–6; Ex. 2107 ¶¶ 54–57, 229–231).

In Reply, Petitioner raises three main arguments. Pet. Reply 9–17. First, Petitioner argues that Patent Owner is improperly disregarding the

express teachings of Steinfeldt-Jensen. *Id.* at 9–10. Specifically, as explained above, Petitioner’s proposed modification of the fifth embodiment of Steinfeldt-Jensen is based on the express disclosure by Steinfeldt-Jensen of an alternative arrangement for the first embodiment. Dr. Slocum, however, suggested that a person of ordinary skill in the art would not have applied that express teaching to the first embodiment, because it was “a really stupid idea,” and likewise wouldn’t apply it to the fifth embodiment either. *Id.* (citing Ex. 1054, 306:23–313:6).

Second, Petitioner argues that Patent Owner’s position is based on a flawed premise—that modifications to Steinfeldt-Jensen are only relevant to insulin pen injectors, whereas Steinfeldt-Jensen and the ’844 patent claims are not limited to *insulin* pen injectors. *Id.* at 11–12 (citing PO Resp. 27–28; Ex. 2107 ¶¶ 44–61; Ex. 1053, 62:13–71:2, 72:3–11, 75:22–76:3). Petitioner asserts that Dr. Slocum “mistakenly assumed” that the person of ordinary skill in the art “was limited to designing a pen for diabetic patients,” which led Dr. Slocum to “incorrectly limit the [person of ordinary skill in the art’s] design objectives to reducing injection force at all costs to accommodate the particular needs of diabetic patients.” *Id.* Petitioner contends that injection force is one factor, but not the only factor, a person of ordinary skill in the art would consider when designing pen injectors, even if directed to diabetic patients. *Id.* at 12 (citing Ex. 1048 ¶¶ 25, 28, 32 (Dr. Biggs explaining that insulin type, cost, reliability, and other factors were more important considerations than injection force when choosing an injectable insulin product); Ex. 1095 ¶ 72).

Third, Petitioner argues that Patent Owner’s models are flawed because (1) the models are unreliable because the physical model was designed by Mr. Veasey, a named inventor on the ’044 patent, not by

Dr. Slocum and Dr. Slocum relied upon Mr. Veasey for many inputs in the analytical model spreadsheet (*id.* at 12–17 (citing Ex. 1053, 12:22–13:5, 28:18–29:2, 30:5–33:13; Ex. 1054, 313:10–325:12; Ex. 1095 ¶¶ 73, 74; Ex. 2107 ¶¶ 242–243)), (2) the models do not assess total change in friction because they focus on friction at one point in the system, but ignore the possibility of reducing friction at other points (*id.* at 15–16 (citing Ex. 1095 ¶¶ 73–75; Ex. 2107 ¶ 58)), and (3) the models were designed to fail because they exaggerate friction losses by not considering changes, within the ordinary level of creativity, that one of ordinary skill in the art could also make to minimize friction (*id.* at 16–17 (citing Ex. 1053, 33:5–13, 41:3–42:13; Ex. 1054, 325:22–327:6; Ex. 1095 ¶¶ 74, 75, 134)).

In its Sur-reply, Patent Owner argues that an increase in injection force “demonstrates that a [person of ordinary skill in the art] would be dissuaded from Petitioner’s modification, even if a [person of ordinary skill in the art] *could* do so,” and that Petitioner offers “no motivation that would outweigh the substantial increase in injection force.” PO Sur-reply 6–7. Patent Owner further argues that the models are not unreliable or biased because “Dr. Slocum independently verified the models, conducted his own experiments, and gathered his own data.” *Id.* at 7–8 (citing Ex. 2017 ¶¶ 242–255, App. B, E). Patent Owner asserts that Mr. Veasey is not an employee of Patent Owner and does not have a financial stake in this proceeding. *Id.* at 8. According to Patent Owner, even assuming Mr. Veasey is an interested party, Petitioner presents no opposing evidence regarding increased friction and injection force. *Id.* Second, Patent Owner contends that the analytical model does test the total change in friction because the 51% increase in injection force is “derived from a comparison between the fifth embodiment and modified fifth embodiment.” *Id.* at 9–10.

Third, Patent Owner argues that Petitioner’s critique of the models as not employing “ordinary creativity” or common-sense approaches to reducing friction is inapposite because any approach could be used to mitigate friction in both the unmodified fifth embodiment as well as the modified fifth embodiment, thus resulting in no offset of total friction. *Id.* at 10.

In consideration of all of the evidence presented, Patent Owner presents persuasive evidence that Petitioner’s proposed modifications would increase friction to some extent. Nonetheless, Steinfeldt-Jensen expressly teaches an alternative configuration wherein a piston rod guide is in wall 4 and a driver tube rotates a nut element instead of a piston rod guide Ex. 1014, 7:41–47. Petitioner also provides persuasive evidence that at least some of the friction increase could be offset by making routine changes well within the level of ordinary skill in the art and that the increase would not have dissuaded one of ordinary skill in the art from applying the alternative disclosed in Steinfeldt-Jensen to the fifth embodiment. *See, e.g.*, Ex. 1095 ¶¶ 73–75.

On the full record before us, we find that Petitioner establishes that despite an increase in friction, one of ordinary skill in the art would not have been dissuaded from modifying Steinfeldt-Jensen’s fifth embodiment as Petitioner proposes. In particular, we credit Petitioner’s evidence that Steinfeldt-Jensen is not limited to insulin injection syringes (*see, e.g.*, Ex. 1014, 1:16–17 (discussing diabetics as a non-limiting example of users who inject themselves frequently and to whom the disclosed injection syringe is directed); Pet. Reply 11–12 (discussing Dr. Slocum’s testimony focusing on diabetic patients), and that, even if the focus were solely on diabetic patients and insulin injection syringes, “[i]njection force is *a* factor

when designing pen injectors, but not the only factor” (*id.* (citing Ex. 1095 ¶ 72)).

d) A Person of Ordinary Skill in the Art Would Not Have Been Dissuaded by Potential Failures in the Flexible Arms of the Alternative Driver Tube from Modifying Steinfeldt-Jensen

Patent Owner argues that there are three other potential failures associated with Petitioner’s proposed modification that would have discouraged a person of ordinary skill in the art from making the modification. PO Resp. 38–39. First, Patent Owner asserts the flexible arms on driver tube 85 could break when subjected to additional frictional. *Id.* at 38. According to Patent Owner, this occurred when Dr. Slocum “attempted to build and test Petitioner’s modification.” *Id.* (citing Ex. 2107 ¶ 240). Second, Patent Owner argues that the flexible arms “may get stuck and prevent the rotation necessary for injection.” *Id.* (citing Ex. 2107 ¶ 239). Third, Patent Owner asserts that the flexible arms “could be pressed into [an opening in the ring-shaped wall], thereby causing the device to fail by jamming the driver tube 85 or causing the flexible arms to pass above the ring-shaped wall such that the driver tube 85 moved proximally into the housing.” *Id.* at 38–39 (citing Ex. 2107 ¶ 239; Ex. 1014, Figs. 14, 15).

In its Reply, Petitioner asserts that Patent Owner’s arguments show that Patent Owner is not applying the perspective of a person of ordinary skill in the art by treating “simple, straightforward tasks” as something that “would stump” a person of ordinary skill in the art. Pet. Reply 17–18. Petitioner asserts that Patent Owner offers no evidence that the flexible arms would be affected, and that, if they were affected, “this would be the type of routine task that a [person of ordinary skill in the art] would have no difficulty addressing,” as explained by Mr. Leinsing. *Id.* at 18 (citing

Ex. 1095 ¶ 76 (referring to Mr. Leinsing's testimony to use a collar as the bearing surface). In its Sur-reply, Patent Owner argues that Mr. Leinsing presents no evidence that addressing these potential failures would be routine. PO Sur-reply 7 (citing Pet. Reply 18 (citing Ex. 1095 ¶ 76)).

As discussed above, Steinfeldt-Jensen expressly describes an alternative configuration wherein a piston rod guide is in wall 4 and a driver tube rotates a nut element instead of a piston rod guide. *See* Ex. 1014, 7:41–47. Steinfeldt-Jensen does not address whether the alternative configuration results in potential failures in the flexible arms of the alternative driver tube. *See id.* Patent Owner's evidence does not support the finding that Petitioner's modification inevitably results in failure or even that failure is necessarily likely to occur more often. Additionally, we find that Petitioner sufficiently establishes that if failure were to occur, a person of ordinary skill in the art would have the means to cure the failure or to modify the mechanism further to mitigate the potential increased frictional force resulting in said failure. *See, e.g.,* Ex. 1095 ¶ 76. For these reasons, we find that even if we accept Patent Owner's arguments that additional potential failures may be likely post-modification, we do not find that those potential failures would dissuade a person of ordinary skill in the art from modifying Steinfeldt-Jensen's fifth embodiment as Petitioner proposes.

e) Determination as to the Reason to Modify

For the reasons above, based on the full record before us, Petitioner persuades us that Steinfeldt-Jensen suggests Petitioner's proposed modifications. In particular, Petitioner persuades us that the expressly taught modification for Steinfeldt-Jensen's first embodiment would have suggested that one of ordinary skill in the art would have had reason to make the same modification to the fifth embodiment in light of the Rotating-Nut

Disclosure, in combination with the General Disclosure, the Rotation Disclosure, and the Driver Disclosure. On these issues, we similarly find the testimony of Mr. Leinsing more persuasive than that of Dr. Slocum, in particular with regard to how and why a person of ordinary skill in the art would have applied Steinfeldt-Jensen's teaching of an alternative rotating-nut drive mechanism from the first embodiment to the fifth embodiment.

3. *Differences Between the Subject Matter of Dependent Claim 22 and the Teachings of Steinfeldt-Jensen*

Claim 22 depends from claim 21 and further requires that "the piston rod has a circular cross-section." Ex. 1004, 8:50–51. Petitioner contends that Figures 15–17 of Steinfeldt-Jensen teach a piston rod that has a circular cross-section. Pet. 56–57 (citing Ex. 1011 ¶ 658). Petitioner provides partial views of Figures 16 and 17, reproduced below:

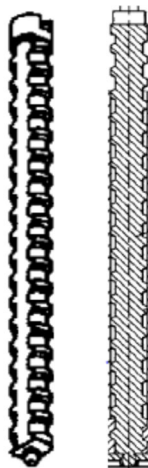

Id. at 56. Illustrated above is piston rod 6 of Steinfeldt-Jensen, as shown in Figure 17 on the left and Figure 16 on the right. Petitioner contends piston rod 6 is shown to have "a circular cross-section at each of its proximal and distal ends," and further asserts that claim 22 does not require that the piston rod have "a uniformly circular cross-section along its entire length." *Id.* at 57 (citing Ex. 1011 ¶ 658). Patent Owner does not dispute that the ends of

piston rod 6 of Steinfeldt-Jensen have a circular cross-section. PO Resp. 30–33.

Petitioner also contends that “piston rod 6 has a ‘circular cross-section’ with flat sides,” as purportedly explained by Mr. Leinsing. Pet. 57 (citing Ex. 1011 ¶ 658). Mr. Leinsing, however, does not support Petitioner’s argument and does not address “flat sides.” *See* Ex. 1011 ¶ 658. We, therefore find Petitioner’s argument unsupported and conclusory. The only issue remaining is whether the claim language is satisfied if, as shown in Steinfeldt-Jensen, only a portion of the piston rod has a circular cross-section.

Patent Owner first argues that piston rod 6 has a non-circular cross-section. PO Resp. 40. That is only half true – portions of piston rod 6 have a non-circular cross-section where the sides are flat, and portions of piston rod 6 have a circular cross-section, most notably at the ends, as shown in the illustrations above. Thus, while Patent Owner is correct that Steinfeldt-Jensen states that piston rod 6 has a “not round” and “non-circular” cross-section, that disclosure does not show that piston rod 6 fails to satisfy the language of claim 22, because the disclosure does not preclude piston rod 6 from having both a circular cross-section and a non-circular cross-section, as illustrated above. PO Resp. 40 (quoting Ex. 1014, Abstract, 11:15–17). Likewise, whether a person of ordinary skill in the art “would understand that the cross-section of the piston rod in Steinfeldt-Jensen is non-circular so that it can slot through and is rotationally constrained to the non-circular bore of driver tube 85,” does not preclude piston rod 6 from having both a circular cross-section and a non-circular cross-section, as illustrated above. PO Resp. 41.

The only responsive argument advanced by Patent Owner is that Petitioner’s interpretation of the claim language “is baseless and not reasonable.” *Id.* at 40–41; PO Sur-reply 15–16. According to Patent Owner:

nowhere in the claim or specification is it suggested that the cross-section of the piston rod is defined by the very ends (e.g., the head) of the piston rod. Rather, the [’]844 Patent specification shows that the piston rod has a circular cross-section over its length because it is adapted to engage with and move rotationally and axially relative to the cylindrical bore in the drive sleeve. *See* Ex. 1004 at 3:65–66, 4:13–14, 6:55–58, Figs. 9–11; Ex. 2107, ¶¶ 418–19.

PO Resp. 41; *see also* PO Sur-reply 15 (arguing that a person of ordinary skill in the art “would have recognized that claim 22 requires a piston rod have a circular cross-section along its length.”). Thus, Patent Owner argues that we should read into claim 22 a limitation that the entire piston rod must have a circular cross-section throughout (“over” or “along”) its length because (1) the specification doesn’t say where the cross-section of the piston rod is defined, and (2) an embodiment shown in the specification has a circular cross-section over its length.¹⁰

The plain language of the claim is not as limited as Patent Owner now suggests and requires only that “the piston rod has a circular cross-section.” The claim does not require a circular cross-section throughout (along or over) the entire length of the piston rod, and Patent Owner offers no persuasive reason for reading such a limitation into the claim. If Patent Owner’s narrow construction of the claim language were correct, a piston

¹⁰ Patent Owner belatedly suggests in its Sur-reply that “common sense and customary usage” would lead a person of ordinary skill to look to the “functional part of the piston rod” to determine the cross-section. PO Sur-reply 15–16. This argument was not raised in the Patent Owner Response and is unsupported by any evidence.

rod that had a circular cross-section along nearly its entire length would not have a “circular cross-section” within the scope of claim 22 if any portion of it did not have a circular cross-section. To the extent Patent Owner implies that the circular cross-section need not be throughout the “entire” length, such a construction would be inconsistent with the plain language of the claim, which does not recite a “circular cross-section” over “most” or “a majority” of the piston rod. It also would be unreasonably vague and ambiguous, because Patent Owner offers no explanation for how a person of ordinary skill in the art would have known whether any particular piston rod satisfied the claim language. Given the choice between construing “the piston rod has a circular cross-section” to mean either the entire piston rod has a circular cross-section or some portion of the piston rod has a circular cross-section, Petitioner has shown that the broadest reasonable construction is the latter. There is no dispute that portions of piston rod 6 have a circular cross-section. Accordingly, we are persuaded that Petitioner shows by a preponderance of the evidence that Steinfeldt-Jensen teaches every limitation of claim 22.

4. *Differences Between the Subject Matter of Dependent Claims 23–29 and the Teachings of Steinfeldt-Jensen*

Claim 23 depends from claim 21 and further requires “a clutch.” Ex. 1004, 8:52–53. Claim 24 depends from claims 23 and further recites “where the clutch provides audible and tactile feedback *indicative* of unit doses of medicament.” Ex. 1004, 8:54–56 (emphasis added). Claim 25 depends from claim 24 and recites “where the clutch provides audible clicks during dose cancelling, where each click is equal to a unit dose of medicament.” *Id.* at 8:57–59. Claims 26–28 also depend from claim 24 and, respectively, require additional limitations related to the clutch and a button

for dose deliver. *Id.* at 8:57–9:3. Claim 29 depends from claim 21 and, similar to claim 25, recites “a clicker that provides audible clicks during dose setting, where each click is equal to a unit dose of medicament.” *Id.* at 9:4–7.

Petitioner shows how Steinfeldt-Jensen teaches every additional limitation of dependent claims 23–29 through a claim chart which provides citations to the disclosures in Steinfeldt-Jensen that correspond to each limitation of the claims. Pet. 57–68. Petitioner’s contentions are supported by Mr. Leinsing. Ex. 1011 ¶¶ 659–684. In sum, Patent Owner does not dispute that Steinfeldt-Jensen teaches every limitation of claims 23–29. *See generally* PO Resp.

Specifically, for example, Petitioner shows that Steinfeldt-Jensen teaches bushing 82, corresponding to the recited “clutch” of claim 23 (and notes that the ’844 patent likewise relies on one element, clutch 60, as both a “sleeve” recited in claim 21 and a “clutch” recited in claim 23). Pet. 58 (citing Ex. 11:34–42; Ex. 1011 ¶¶ 659, 660). With regard to the recited clicking features, Petitioner shows, and Patent Owner does not dispute, that “Steenfeldt-Jensen taught a clicking system that operates by having protrusion 87 extend from bushing 82 into a number of depressions or recesses such that the spacing of the depressions or recesses causes tactile and audible feedback as the protrusions snap into the depressions when dose-setting button 81 is rotated ‘in any direction.’” Pet. 59–60 (citing Ex. 1014, 6:48–54, 11:37–40, 11:62–67; Ex. 1011 ¶¶ 662, 663). There also is no dispute that Steinfeldt-Jensen teaches both “audible and tactile feedback indicative of unit doses of medicament,” as well as “audible clicks during dose setting, where each click is equal to a unit dose of medicament,” as recited in the Challenged Claims. *See* Pet. 59–62; Ex. 1014, 6:42–53.

Petitioner also shows that Steinfeldt-Jensen teaches dose-setting button 88 corresponding to the recited “button” and features of claims 27 and 28. Pet. 64–68 (citing, e.g., Ex. 1014, 11:34–42, 11:49–51; Ex. 1011 ¶¶ 671–674).

We are persuaded that Petitioner shows by a preponderance of the evidence that Steinfeldt-Jensen teaches every limitation of claims 23–29 for the reasons identified in the Petition (pages 57–68 (citing Ex. 1014, 1:20–22, 2:24–28; 4:59–60, 5:60–62, 5:64–6:3, 6:48–54, 8:48–53, 11:22–25, 11:34–67, 12:1–13, Figs. 15–17)), which we adopt as our own findings.

5. *Objective Indicia of Nonobviousness*

We next consider evidence of objective indicia of nonobviousness related to a product that Patent Owner asserts practices claims of the ’844 patent and “satisfied a long-felt need in the industry,” received industry praise, and attained “overwhelming commercial success.” PO Resp. 3, 42–54; PO Sur-reply 17–23. Petitioner argues in response that Patent Owner fails to show a nexus between the purported evidence of objective indicia of nonobviousness and the Challenged Claims and that the offered evidence fails to support Patent Owner’s contentions. Pet. Reply 22–27.

As background to Patent Owner’s arguments, Patent Owner sold an insulin glargine solution administered as a once-daily subcutaneous injection for patients diagnosed with either Type 1 or Type 2 diabetes under the tradename Lantus® in three different forms. Ex. 2109 ¶¶ 6, 17. The first form launched in the United States in 2001 as “Lantus® vial” and is administered through a syringe. *Id.* ¶¶ 6, 18. The second form launched in the United States in 2005 in a pen injector form as “Lantus® OptiClik®,” but was subsequently discontinued and allegedly did not practice the

'844 patent. Ex. 2109 ¶¶ 19, 36; Ex. 2107 ¶¶ 644–648. The third form launched in the United States in 2007 in a pen injector form as “Lantus[®] SoloSTAR[®].” Thereafter, in addition to Lantus[®], a “long-acting insulin analog,” Patent Owner also sold “fast-acting” injectable insulin with the SoloSTAR[®] pen injector, including Apidra[®] SoloSTAR[®] and Admelog[®] SoloSTAR[®]. Ex. 2109 ¶¶ 6, 17, 22; Ex. 1048 ¶ 39. Patent Owner also explains that at the time of the invention of the '844 patent “there were already several pen-type injectors known in the art,” including the commercially available Novo Nordisk FlexPen[®] which “closely corresponds” to an embodiment described in Steinfeldt-Jensen and which was marketed for administering an insulin analog as the “Levemir[®] FlexPen[®].” PO Resp. 3–4 (citing Ex. 1014, Figs. 1–17; Ex. 2107 ¶ 28), 45, 50.

According to Patent Owner, the SoloSTAR[®] pen injector practices claims 21 and 30 of the '844 patent. PO Resp. 3; Ex. 2109 ¶ 20; Ex. 2107 ¶¶ 551–610. Patent Owner’s contention is persuasively supported by Dr. Slocum’s unrebutted testimony that the SoloSTAR[®] pen injector practices claims 21 and 30 of the '844 patent. Ex. 2107 ¶ 551–610; *see id.* ¶ 551 (stating that “it is my opinion that the SoloSTAR[®] device practices at least claims 21 and 30 of the '844 patent”). Accordingly, based on Dr. Slocum’s testimony, Patent Owner shows that SoloSTAR[®] practices claims 21 and 30 of the '844 patent.

Patent Owner, however, does not focus its arguments of objective evidence of nonobviousness on SoloSTAR[®] alone (with the exception of industry praise), but instead proceeds to argue that “Sanofi’s Lantus[®] SoloSTAR[®] practices claims 21 and 30” of the '844 patent. PO Resp. 43 (footnote omitted). Importantly, none of the Challenged Claims of the

'844 patent recite Lantus[®] or any other medication as a required limitation. Presumably, Patent Owner implicitly reasons that because SoloSTAR[®], a pen injector for administering a medication, practices the Challenged Claims, the same pen injector sold as a combination product with medication, Lantus[®], necessarily also practices the claimed invention. Petitioner does not dispute Patent Owner's contention and we are persuaded that Lantus[®] SoloSTAR[®] practices claims 21 and 30 of the '844 patent for the same reasons Patent Owner sufficiently established that SoloSTAR[®] practices the same claims.

As a brief summary of the legal standards we apply with regard to evidence of objective indicia of nonobviousness, we emphasize that such indicia are “only relevant to the obviousness inquiry ‘if there is a nexus between the claimed invention and the [objective indicia of nonobviousness].’” *In re Affinity Labs of Tex., LLC*, 856 F.3d 883, 901 (Fed. Cir. 2017) (quoting *Ormco Corp. v. Align Tech., Inc.*, 463 F.3d 1299, 1312 (Fed. Cir. 2006)). A patentee is entitled to a presumption of nexus “when the patentee shows that the asserted objective evidence is tied to a specific product and that product ‘embodies the claimed features, and is coextensive with them.’” *Fox Factory, Inc. v. SRAM, LLC*, 944 F.3d 1366, 1373 (Fed. Cir. 2019) (quoting *Polaris Indus., Inc. v. Arctic Cat, Inc.*, 882 F.3d 1056, 1072 (Fed. Cir. 2018) (quoting *Brown & Williamson Tobacco Corp. v. Philip Morris Inc.*, 229 F.3d 1120, 1130 (Fed. Cir. 2000))). If the patented invention is only a component of a commercially successful machine or process, the patentee is not entitled to a presumption of nexus. *Id.* (reaffirming the importance of the “coextensiveness” requirement). “[T]he purpose of the coextensiveness requirement is to ensure that nexus is only presumed when the product tied to the evidence of secondary

considerations ‘is the invention disclosed and claimed.’” *Id.* at 1374 (quoting *Demaco Corp. v. F. Von Langsdorff Licensing Ltd.*, 851 F.2d 1387, 1392 (Fed. Cir. 1988)). “[T]he degree of correspondence between a product and a patent claim falls along a spectrum. At one end of the spectrum lies perfect or near perfect correspondence. At the other end lies no or very little correspondence.” *Id.* “A patent claim is not coextensive with a product that includes a ‘critical’ unclaimed feature that is claimed by a different patent and that materially impacts the product’s functionality.” *Id.* at 1375.

Patent Owner does not argue that Lantus[®] SoloSTAR[®] is coextensive (or nearly coextensive) with any of the Challenged Claims, which do not require medication. Accordingly, to the extent that Patent Owner relies on evidence based on Lantus[®] SoloSTAR[®] to show objective indicia of nonobviousness, Patent Owner does not show that it is entitled to a presumption of nexus.

However, “[a] finding that a presumption of nexus is inappropriate does not end the inquiry into secondary considerations.” *Fox Factory*, 944 F.3d at 1375. “To the contrary, the patent owner is still afforded an opportunity to prove nexus by showing that the evidence of secondary considerations is the ‘direct result of the unique characteristics of the claimed invention.’” *Id.* at 1373–74 (quoting *In re Huang*, 100 F.3d 135, 140 (Fed. Cir. 1996)). “Where the offered secondary consideration actually results from something other than what is both claimed and *novel* in the claim, there is no nexus to the merits of the claimed invention,” meaning that “there must be a nexus to some aspect of the claim not already in the prior art.” *In re Kao*, 639 F.3d 1057, 1068–69 (Fed. Cir. 2011) (emphasis in original). Additionally, there is no requirement that “objective evidence must be tied exclusively to claim elements that are not disclosed in a

particular prior art reference in order for that evidence to carry substantial weight.” *WBIP, LLC v. Kohler Co.*, 829 F.3d 1317, 1331 (Fed. Cir. 2016). A patent owner may show, for example, “that it is the claimed combination as a whole that serves as a nexus for the objective evidence; proof of nexus is not limited to only when objective evidence is tied to the supposedly ‘new’ feature(s).” *Id.*

Indeed, Patent Owner argues, as to the claimed invention of the ’844 patent, that the components recited in the Challenged Claims “work together” to provide a device that is “easy to use” and that yields “a combination of desirable features and properties, such as (i) low injection force, (ii) short injection stroke length or higher maximum dose per injection, and (iii) a relatively small number of components that decrease the complexity of the device.” PO Resp. 43 (citing Ex. 2107 ¶ 650). To be clear, these alleged “features and properties” do not correspond to any recited limitation in any of the Challenged Claims. As Petitioner explains, Lantus® SoloSTAR® “is not ‘the invention’ of these claims,” because “the claims do not require Lantus[®] (or insulin at all), an 80-unit cartridge, a particular stroke length or injection force.” Pet. Reply 22. Moreover, Patent Owner offers no objective definition or explanation of what constitutes an “easy to use” pen injector, a “low injection force,” a “short injection stroke length,” a “higher maximum dose,” or a “relatively small number of components.”

Ultimately, the fact finder must weigh the secondary considerations evidence presented in the context of whether the claimed invention as a whole would have been obvious to a skilled artisan. *WBIP*, 829 F.3d at 1331–32. Once the patentee has presented a *prima facie* case of nexus, the burden of coming forward with evidence in rebuttal shifts to the

challenger “to adduce evidence to show that the commercial success was due to extraneous factors other than the patented invention.” *Demaco*, 851 F.2d at 1393. Below we consider in more detail the evidence and argument provided by the parties with regard to any purported long-felt need, industry praise, and commercial success in light of the alleged nexus to the required features of the Challenged Claims of the ’844 patent.

a) Long-Felt, Unmet Need

Patent Owner contends that “Lantus[®] SoloSTAR[®] satisfied long-felt, but unresolved needs existing in commercially available pen injectors.” PO Resp. 44–47; PO Sur-reply, 21–23; *see also* Pet. Reply 23–25 (disputing Patent Owner’s contentions of long-felt need). Specifically, Patent Owner contends its product “satisfied a long-felt but unmet need for an easy-to-use pen that was particularly well suited to administer medication with a low injection force.” PO Resp. 47.

Based on Dr. Goland’s testimony, Patent Owner asserts that “diabetic patients need an easy-to-use injection device with a low injection force to reduce the burden on the patient and increase the likelihood of the patient adhering to their prescribed therapy.” *Id.* at 44–45 (citing Ex. 2111 ¶¶ 22–26). Patent Owner further explains that “[p]rior to the launch of Lantus[®] SoloSTAR[®], there were multiple injection pens on the market for administering insulin or an insulin analog,” but they all required “significant injection force” and that “made the devices difficult to use and thus increased the risk of patients not adhering to their insulin and insulin-analog therapy.” *Id.* at 45 (citing Ex. 2107 ¶ 646; Ex. 2109 ¶¶ 52–55; Ex. 2111 ¶¶ 23–25, 33–35; Ex. 2143; Ex. 2144).

Patent Owner argues that “Lantus[®] SoloSTAR[®] revolutionized the injection pen market, in large part because the Lantus[®] SoloSTAR[®] was easy

to use,” and attributes that ease of use to the “reduced injection force,” which Patent Owner characterizes as “a primary concern.” *Id.* at 45–46 (citing Ex. 2111 ¶ 33; Ex. 2116, 7; Ex. 2142). According to Patent Owner, “the primary intent of the invention” of the ’844 patent is described in the patent as an embodiment that “helps reduce the overall force required for a user to cause medicinal product to be dispensed.” *Id.* at 46 (quoting Ex. 1004, 4:7–9). Patent Owner also identifies a “related patent” that describes presumably the same “drive mechanism” as the one taught in the ’844 patent as “an alternative for drive mechanisms, wherein reduced force is needed to actuate the mechanism.” *Id.* (quoting Ex. 1005, 1:66–2:3).

In support of its contention that “Lantus[®] SoloSTAR[®] satisfied a long-felt, unmet need, Patent Owner argues that “[t]he industry extensively recognized SoloSTAR[®] for solving the problem of needing to deliver high doses with a short dial extension and with low injection force,” and that patients “expressed a preference for SoloSTAR[®] for its low injection force.” *Id.* at 46–47 (citing Ex. 2117; Ex. 2121, 2, 9; Ex. 2123, 6; Ex. 2128; Ex. 2143; Ex. 2144; Ex. 2184, 2; Ex. 2185, 1).

(1) Patent Owner Fails to Show a Nexus Between the Purported Evidence of Alleged Long-felt Need and Any Challenged Claim of the ’844 Patent

There is no dispute that none of the Challenged Claims recite or otherwise require a low injection force, the ability to deliver high doses, or a short dial extension. Thus, to show that the Challenged Claims satisfied a long-felt, unmet need for an injection pen with these features, Patent Owner must show that the purported low injection force, ability to deliver high doses, and/or short dial extension is the direct result of the unique characteristics of the claimed invention. *Fox Factory*, 944 F.3d at 1373–74.

Patent Owner fails to carry this burden. The entirety of Patent Owner's argument and evidence on this specific issue consists essentially of the assertion that Dr. Slocum explained that "the inventions in the challenged claims describe a set of components that elegantly work together." PO Resp. 43 (citing Ex. 2107 ¶ 650); *see also id.* at 44 (stating that "due to the contributions of the above features described by" Dr. Slocum, "the Lantus[®] SoloSTAR[®] satisfied long-felt, but unresolved needs existing in commercially available pen injectors"); *see also* PO Sur-reply 19 (stating that "the challenged claims enable SoloSTAR[®]'s low injection force and other features identified in the Response").

We have considered Dr. Slocum's testimony and find it insufficient to support Patent Owner's contentions. In his declaration, Dr. Slocum addressed how SoloSTAR[®] practices claims of *four different patents*, including the '844 patent. Ex. 2107 ¶¶ 439–649. Dr. Slocum then addresses in a single paragraph, reproduced below, the "Benefits of the Claims of the Challenged Patents":

In my opinion, the claimed components and interfaces, such as the threaded engagements, piston rod, drive sleeves/driving members, dose stops, and clutch enable an injection device with (i) low injection force, (ii) short or long injection stroke length for low or high dose per injection, and (iii) a relatively small number of components that decrease the complexity and cost of the device. The arrangement of components limits the frictional losses in the mechanism, thereby providing an efficient force transmission from the user's hand to the injection piston in the ampoule that contains the medicament. The challenged claims also enable a device without a "resetting" operation, thereby making the injection pen easier to use. The challenged claims further enabled an injection device with a shorter dial extension, providing additional benefits for patients lacking dexterity. Specifically, the SoloSTAR[®] has a maximum of 80 units, while the FlexPen[®] only has a maximum of 60 units.

While the SoloSTAR[®]'s dial would extend to 25.5mm to inject 60 units, the FlexPen[®] must extend to 33mm to inject 60 units. All of these features are evidenced in the SoloSTAR[®] injector pen which practices the inventions of the challenged claims. The embodiments described in the challenged patents also show that these advantages can be realized by a small number of components, thereby enabling a device that can be manufactured at lower cost. Also, because the pen is disposable, the components can be made of inexpensive materials, thereby further reducing the production costs.

Ex. 2107 ¶ 650. Dr. Slocum fails to explain which “claimed components and interfaces” of which patents he is specifically referring to among the four patents discussed in his declaration, and fails to address how any of the purported benefits are the “the direct result” of any “unique characteristics of the claimed invention.” We agree with Mr. Leinsing that Dr. Slocum “provides no analysis as to how these claims supposedly enabled the benefits identified in paragraph 650 of his declaration, including low injection force, dose dial stroke length, and a small number of components.” Ex. 1095 ¶ 156 (further explaining that “a person of ordinary skill would have understood that the components recited in the claims would not have necessarily provided any of these benefits, either alone or collectively,” and “would have understood the claims as broadly including embodiments lacking all of these supposed benefits”).

More critically, Dr. Slocum's opinion that some set of components recited in the '844 patent “enable an injection device” with certain features, such as “low injection force” is, on its face, insufficient to establish the necessary nexus. As we explained above, the evidence of secondary considerations, here the “low injection force,” must be shown to be the “direct result of the unique characteristics of the claimed invention.” *Fox Factory*, 944 F.3d at 1373–74 (quoting *In re Huang*, 100 F.3d 135, 140

(Fed. Cir. 1996)). Merely “enabling” a “low injection force” means that the injection force may, or may not be “low,” depending upon some other consideration, and, therefore, it is not “the direct result” of any claimed feature. In other words, setting aside the ambiguity of what constitutes a “low injection force,” Patent Owner provides no evidence that a pen injector made in accordance with any Challenged Claim will necessarily result in a device with a “low injection force.”

The same is true of the other purported benefits identified by Dr. Slocum. For example, Dr. Slocum states that some set of components recited in the ’844 patent “enable an injection device” with “a relatively small number of components that decrease the complexity and cost of the device.” The Challenged Claims do not require a “small number of components,” and Patent Owner provides no evidence that a pen injector made in accordance with any Challenged Claim will necessarily result in a device with a “a relatively small number of components that decrease the complexity and cost of the device.” Likewise, “injection stroke length” and “dose per injection” are unclaimed features purportedly “enabled,” but not shown to be a “direct result” of any set of elements recited by any Challenged Claim. Thus, we find that Patent Owner fails to establish a nexus between the purported evidence of alleged long-felt need for a pen with a low or reduced injection force (or the ability to deliver high doses or a short dial extension) and any claim of the ’844 patent at issue in this proceeding.

(2) Patent Owner Fails to Show the Existence of a Long-felt, but Unresolved Need

Patent Owner does not show that a long-felt, but unresolved need existed at the time of the invention for “an easy-to-use pen that was

particularly well suited to administer medication with a low injection force.” See PO Resp. 47. The Federal Circuit has explained that “[l]ong-felt need is closely related to the failure of others,” and that “[e]vidence] is particularly probative of obviousness when it demonstrates both that a demand existed for the patented invention, and that others tried but failed to satisfy that demand.” *Eurand, Inc. v. Mylan Pharms., Inc. (In re Cyclobenzaprine Hydrochloride Extended-Release Capsule Patent Litig.)*, 676 F.3d 1063, 1082 (Fed. Cir. 2012). Establishing a long-felt need requires objective evidence that the invention has provided a long-awaited, widely accepted, and promptly adopted solution to a problem existent in the art, or that others had tried but failed to solve that problem. See *In re Mixon*, 470 F.2d 1374, 1377 (CCPA 1973). Furthermore, one must demonstrate that “widespread efforts of skilled workers having knowledge of the prior art had failed to find a solution to the problem.” *In re Allen*, 324 F.2d 993, 997 (CCPA 1963). Patent Owner’s contentions and evidence fail to establish any failure of others, any unsatisfied demand, any long-awaited solution to a problem, or any other persuasive basis to show the existence of a long-felt need at the time of invention.

As an initial matter, Patent Owner fails to identify an objective means to measure or compare the ease of use of pen injectors to support the notion that a long-felt need existed for an “easy-to-use” injection device. See PO Resp. 44–48; PO Sur-reply 21–24. Dr. Goland suggests that “prior injection pen devices available prior to the launch of Lantus[®] SoloSTAR[®] were more difficult to use than Lantus[®] SoloSTAR[®] and had a higher injection force, meaning the devices required significantly more force by the patient’s thumb to depress the button to administer the medication.” Ex. 2111 ¶ 4.

Dr. Goland does not quantify to what degree SoloSTAR[®] was easier to use

and merely suggests that “[m]y patients overall prefer Lantus® SoloSTAR® over all other available pen injection devices.” *Id.* ¶ 16; *see also id.* ¶¶ 27–30 (stating that OptiClik® “had a much higher injection force,” that FlexPen® “has a relatively high injection force,” and that “other devices suffered from the same shortcomings”).

By contrast, Dr. Biggs highlights that “affordability” is more important to “ease of use” for patients than injection force, particularly in terms of patient adherence. Ex. 1048 ¶¶ 34, 35. Dr. Biggs states that SoloSTAR® was “welcomed by Lantus® users as a significant improvement over Sanofi’s defective OptiClik® pen but was not recognized as an unusually good pen in itself.” *Id.* ¶ 43; *see also id.* ¶¶ 49, 50 (discussing reasons the OptiClik® pen was unsatisfactory). According to Dr. Biggs, “insulin drives the prescription, with the delivery mode being determined by the modes available from the prescribed insulin’s manufacturer,” and Lantus® SoloSTAR® “is prescribed frequently” because Lantus® “is a popular insulin,” not because SoloSTAR® “is a remarkable pen.” *Id.* ¶ 44. The notion of a long-felt need for an “easy-to-use” device is, at best, ambiguous in application. Dr. Goland, on behalf of Patent Owner, demonstrates the ambiguity and lack of objective evidence inherent in Patent Owner’s argument by explaining that “the primary reason that the SoloSTAR® pen is so easy-to-use is because of the low injection force,” but then stating that SoloSTAR® is “easier” because of a “short dial extension length,” is “also easy to use because it includes the ability to dial up and dial back a desired dose, and provides tactile and audible feedback, portability, and ease of handling,” has a “last dose stop” that “patients have found . . . contribute[s] to the device being easy to use,” and is “disposable.” Ex. 2111 ¶ 33–39. Patent Owner fails to demonstrate any established

measure of what constitutes a device that is “easy-to-use,” but rather shows that there are many considerations that account for the ease of use of any device.

The evidence developed demonstrates that SoloSTAR[®] was not the first “easy to use” injection pen or that all of the competing pen injectors were not easy to use because they lacked a sufficiently “low” injection force. In fact, Patent Owner concedes that “[p]rior to the launch of Lantus[®] SoloSTAR[®], there were multiple injection pens on the market for administering insulin or an insulin analog – *e.g.*, Levemir[®] FlexPen[®] and Lantus[®] OptiClik[®] in the long-acting category, and the Humalog KwikPen in the rapid-and intermediate-acting categories, among many others.” PO Resp. 45. Likewise, Dr. Biggs explained that other insulin pens were available and fungible with Lantus[®] SoloSTAR[®]. *See* Pet. Reply 23–24 (citing Ex. 1046, 9, 37, 39, 57, 62, 63, 75; Ex. 1048 ¶¶ 27, 29, 32–44–47, 51–53, 56; Ex. 2126, 1, 3; Ex. 2143, 1, 5, 9, 10, 70; Ex. 2145, 26). Dr. Biggs also persuasively establishes that “[a]vailable pens at the 2003 filing date were already considered “easy-to-use, convenient, and accurate.” Ex. 1048 (citing Ex. 1046, 57, 62). Further, the evidence establishes that:

- “other insulin pens were already considered easy to use both generally and for patients with special challenges like age or dexterity issues,” (Pet. Reply 24 (citing Ex. 1048 ¶¶ 45–47, 52; Ex. 1046, 57, 62, 63¹¹);
- Sanofi’s studies confirm that both SoloSTAR[®] and FlexPen[®] were “very easy to use;” Ex. 2145, 26; *see also* Ex. 1048 ¶ 55;

¹¹ Unless otherwise noted, citations rely on the pagination of the original document for articles and studies.

Ex. 2126, 1157 (stating that “the SoloSTAR[®] and FlexPen[®] were more user-friendly”); Ex. 2143, 650, 659 (stating that “both the SoloSTAR[®] pen and FlexPen[®] were found to have high patient usability”), 656 (stating that “the FlexPen[®] was also found to be user-friendly”);

- Sanofi’s studies concluded both the SoloSTAR[®] and FlexPen[®] were suitable in both elderly and younger patients and those with visual and dexterity impairments, and “were associated with comparable usability;” Ex. 2126, 1159; *see also* Ex. 1048 ¶ 56; Ex, 2143, 654, 658; and that,
- SoloSTAR[®] was a “best-performing pen device *in a statistical tie with FlexPen*,” Ex. 2146, 9); *see also* Ex. 1048 ¶ 52; Ex. 2146, 37, 39, 75).

We find the evidence provided by Petitioner of no long-felt, unmet need discussed above more credible than Dr. Goland’s insufficiently supported statement that “other pen devices . . . had too high of an injection force for my patients.” *See* Ex. 2111 ¶ 42.

In sum, Patent Owner’s evidence may demonstrate acceptance of Lantus[®] SoloSTAR[®] (*see, e.g.*, Ex. 2184, 1; Ex. 2185, 1; Ex. 2121, 6), but it does not show any failure of others, any unsatisfied demand, or any long-awaited solution to any problem. The mere fact that a pen injector with a lower injection force might, or might not, be preferable over other readily available and effective pen injectors, depending upon various considerations, including cost and medication, fails to show a long-felt, unmet need for a pen injector with a lower injection force. Accordingly, the evidence provided by Patent Owner does not demonstrate a long-felt need existed for

an “easy-to-use” injection device corresponding to any of the features Patent Owner attributes to SoloSTAR[®].

(3) Patent Owner Fails to Show that Lantus[®] SoloSTAR[®] Satisfied a Purported Long-felt, but Unresolved Need

As discussed above, Patent Owner contends its product “satisfied a long-felt but unmet need for an easy-to-use pen that was particularly well suited to administer medication with a low injection force.” PO Resp. 47. Given the ambiguity in Patent Owner’s identification of any purported “long-felt, but unmet need,” it is virtually impossible to determine whether SoloSTAR[®] met the need. What we can conclude is that Patent Owner does not show that the injection force of SoloSTAR[®] made it the easiest-to-use pen “particularly well suited to administer medication” ever invented at the time. Whether SoloSTAR[®] even provides a “low injection force” is in dispute and depends upon what study is relied upon and what other devices it is being compared to.

Patent Owner relies on the opinions of Dr. Slocum and Dr. Goland, who, in turn, cite studies and internal marketing materials produced by Patent Owner to show that SoloSTAR[®] provides a reduced injection force, at least with respect to certain devices to which it was compared. PO Resp. 45–46; (citing Ex. 2111 ¶¶ 23–25; Ex. 2109 ¶¶ 52–55); *see also* Ex. 2111 ¶¶ 32, 33 (citing Ex. 2116, 9; Ex. 2123, 6; Ex. 2143, 7; Ex. 2144, 5, 9–11). For example, Dr. Grabowski states that “[o]ne study found that, with respect to injection force, ‘SoloSTAR[®] was preferred by a significantly greater number of patients as their first choice (65%) compared with other pens assessed,’ including Novolog[®] FlexPen[®] and Lilly's disposable pen.” Ex. 2109 ¶ 53 (citing Ex. 2126, 1159). The study Dr. Grabowski cites, however, characterizes its finding as “[r]egarding injection performance,”

not “injection force” as indicated by Dr. Grabowski, who does not otherwise explain whether the terms are coextensive or whether “injection performance” includes features other than “injection force.” Dr. Grabowski also states that another study “compared the injection force of the SoloSTAR[®] pen to competitor pens” and “concluded that ‘SoloSTAR[®] stands out because of its low injection force, even when compared with newer insulin pen devices such as the KwikPen and NGFP [Next Generation FlexPen[®]].” *Id.* (citing Ex. 2100, 150). The study relied upon by Dr. Grabowski was limited to “Other Disposable Insulin Pen Devices” and states that it was authored by “an employee of sanofi-aventis” and acknowledges that “[e]ditorial support was provided by Global Publications group of sanofi-aventis.” Ex. 2100, 150, 155.

Petitioner argues that, in contrast to the “Sanofi-sponsored injection force studies” relied upon by Patent Owner (*e.g.*, Ex. 2143; Ex. 2144; Ex. 2100; Ex. 2126; Ex. 2116; Ex. 2123), other studies found that SoloSTAR[®] did not have a lower injection force. Pet. Reply 24 (citing Ex. 1048 ¶ 58; Ex. 2145, 15 (the “US Lantus SoloSTAR Launch Book,” stating in regard to SoloSTAR[®] that “[e]asier to inject’ was not supported by two studies showing data versus FlexPen[®] and Lilly pen”); *see also* Ex. 2145, 17–18 (stating that “SoloSTAR[®] has one of the lowest injection forces of all pens, but not the lowest,” that the “Innolet disposable pen has the lowest injection force of all disposable and reusable pens,” and that “NovoPen 4 injection force if very similar to SoloSTAR[®]”). Dr. Biggs also raised issues with the methodology of at least some of the studies relied on by Patent Owner. Ex. 1048 ¶ 58 n.3.

With regard to Dr. Slocum’s opinion that SoloSTAR[®] provided “a shorter dial extension,” “has a maximum of 80 units, while the FlexPen[®]

only has a maximum of 60 units,” and has a dial that “would extend to 25.5mm to inject 60 units, [whereas] the FlexPen[®] must extend to 33mm to inject 60 units,” we find no sufficient evidence to show that any of these purported features provided a benefit over prior art pen injectors that satisfied any purported long-felt need. *See* Ex. 2107 ¶ 650. Dr. Biggs characterizes any difference between the maximum extension of SoloSTAR[®] compared to FlexPen[®] as “difficult to discern visually” and “too slight to be of practical consequence.” *Id.* ¶ 55.

We further find unpersuasive Patent Owner’s argument that “[t]he industry extensively recognized SoloSTAR[®] for solving the problem of needing to deliver high doses with a short dial extension and with low injection force.” PO Resp. 46–47. As support, Patent Owner relies not on an industry publication, but a study “supported by Sanofi-Aventis” that received “[e]ditorial support” from “Global Publications group of Sanofi-Aventis.” Ex. 2128, 121. Under the heading “Unmet needs,” the study states that “many patients need to administer doses of insulin exceeding 60 units, the maximum dose of many insulin pens.” *Id.* at 115. Dr. Biggs explains that there was “no unmet need in 2003 for an 80U pen” because “the Disetronic pen offered this feature years earlier.” Ex. 1048 ¶ 56 (citing Ex. 1046, 82–83). We agree. We have considered all of the additional “industry” recognition cited by Patent Owner, including Exhibit 2123 (a study funded by Sanofi that found that, when compared to a limited set of certain other pens, Lantus[®] pens, KlikSTAR[®] and SoloSTAR[®], “require a significantly lower injection force compared with the reusable or prefilled insulin pens containing the insulin glargine copies”) and Exhibit 2184 (an article from the “Philippine Daily Inquirer” stating “the Lantus[®] SoloSTAR[®] operates with a low injection force?31 [sic] percent less than other insulin

pens ?that [sic] allows a gentle injection.”¹² PO Resp. 47. Patent Owner also cites Exhibit 2185 as reflecting a statement from a Professor of Endocrinology in France that “[i]nsulin injection with SoloSTAR[®] brings flexibility, satisfaction for the patients, and an opportunity for earlier initiation of insulin therapy which may contribute to better long term glycemic control.” *Id.* (quoting Ex. 2185, 1). Patent Owner fails to explain how that statement supports the contention that SoloSTAR[®] satisfied any long-felt, unmet need. The same applies to Patent Owner’s purported evidence of patient preferences. *Id.* (citing; Ex. 2121, 2, 9; Ex. 2143; Ex. 2144).

We have further considered and find not persuasive all of Patent Owner’s additional arguments, including that SoloSTAR[®] was preferred over OptiClik, that earlier FlexPens were hard to push, that some patients did not take their insulin because prior art devices were problematic, and that patients were transitioned to SoloSTAR[®] because of its lower injection force. PO Sur-reply 22 (citing Ex. 1056, 34:3–17, 35:7–12; 66:9–15; Ex. 2100; Ex. 2111 ¶¶ 31–43; Ex. 2113; Ex. 2116; Ex. 2121; Ex. 2123; Ex. 2126; Ex. 2128; Ex. 2140; Ex. 2143; Ex. 2144; Ex. 2184; Ex. 2185). Patent Owner also argues that Mr. Leinsing acknowledges a focus on reducing injection force (*id.* (citing Ex. 2316, 80:24–81:1)); that patients would have disliked Dr. Biggs suggestion that “any long-felt need was satisfied by the Lantus[®] vial and syringe, that patients complaining of injection force could have caregivers . . . administer their treatments, and

¹² Patent Owner alters the statement from what appears in Exhibit 2184 and also attributes it to a particular individual, however, the article does not make clear from whom the information is coming. *Compare* PO Resp. 51 *with* Ex. 2184, 2.

that patients could carry around . . . preloaded syringes” (*id.* (citing Ex. 1048 ¶¶ 31–32; Ex. 1056, 52:23–53:25, 58:18–59:24; Ex. 2317, 70:10–19, 84:24–85:14)), and that Dr. Biggs’s testimony is undermined by his admission that his suggestions may not be covered under Medicare or insurance and that the majority of his patients switched from Lantus[®] vial to Lantus[®] SoloSTAR[®], which most patients preferred (*id.* at 22–23 (citing Ex. 2317, 38:7–39:3, 115:23–116:6, 118:19–22)).

Based on the entirety of the evidence provided by both parties, we conclude for the reasons provided above that the evidence does not support Patent Owner’s argument that SoloSTAR[®] satisfied a long-felt but unmet need for a pen with “a low injection force,” because there were other injection pens that operated with similar and even lower injection forces than SoloSTAR[®]. Likewise, Patent Owner does not show persuasively that the dial extension or maximum dosing of SoloSTAR[®] exceeded any other injection pen available when it was introduced or at the time of the invention of the ’844 patent to support the contention that it satisfied a long-felt but unmet need.

b) Industry Praise

Patent Owner contends that the “nonobviousness of the [’]844 patent is further demonstrated by the high level of praise and industry recognition that Sanofi and DCA, the design firm with whom Sanofi partnered in creating SoloSTAR[®], received for the designs embodied in the SoloSTAR[®] device.” PO Resp. 48.

First, Patent Owner states that SoloSTAR[®] “won the Gold, International Export, and Grand Prix awards at the Design Business Association (DBA) Design Effectiveness Awards” in 2009. *Id.* (citing Ex. 2121). According to Patent Owner, “[t]he DBA is a design organization

based in the UK that is interested in how a design commercially impacts a company's business.” *Id.* Patent Owner asserts that “[t]he case study of SoloSTAR[®] for the DBA Awards describes the SoloSTAR[®]'s inventiveness as ‘suitably ambitious’ and explains that ‘SoloSTAR[®] is the first disposable insulin pen to combine very low injection force (which provides a smooth injection experience for patients) with 80 units maximum dose capability, an important breakthrough.’” *Id.* (citing Ex. 2121, 3).

Petitioner responds that the “case study of SoloSTAR[®]” Patent Owner relies upon was “written, funded, and sponsored by Sanofi” with DCA, and is “self-praise, not industry praise.” Pet. Reply 25 (citing Ex. 1055, 79:6–81:19). Consistent with Petitioner's argument, the document Patent Owner relies upon in support of its contentions, Exhibit 2121, bears the names “DCA” and “Sanofi Aventis” at the top of each page and reflects information they provided for consideration as part of the “DBA Design Effectiveness Awards 2009.” Ex. 2121, 1; *see also* Ex. 1060 (according to Dr. McDuff, the “DBA web site gives applicants like Sanofi and DCA tips on how to prepare the case studies applicants write”). Exhibit 2121 does not indicate any award was given to SoloSTAR[®], much less why any award was given to SoloSTAR[®].

The only evidence of actual industry praise offered by Patent Owner in this regard is Dr. Grabowski's statement that “[i]n 2009, at the Design Business Association (“DBA”) Design Effectiveness Awards, Sanofi won the Gold, International Export, and Grand Prix awards.” Ex. 2109 ¶ 72. Dr. Grabowski fails to offer any explanation or evidence to show what these awards mean, how they were awarded, or why they were awarded for SoloSTAR[®]. Dr. Grabowski instead refers back to the case study prepared by Patent Owner and DCA, Exhibit 2121. *Id.* We find that Exhibit 2121

does not constitute “industry praise” because it was prepared by Patent Owner and DCA and does not reflect the opinion of the industry or even the receipt of praise. Nor can we reach any conclusion about the “Design Effectiveness Awards” Dr. Grabowski states were given for SoloSTAR[®] in the absence of any evidence explaining what any of the awards entail.

Second, Patent Owner states that “SoloSTAR also won the Good Design Award by the Chicago Athenaeum Museum of Architecture and Design.” PO Resp. 48 (citing Ex. 2201). According to Dr. Grabowski, “[t]he criteria for this award are ‘quality design of the highest form, function, and aesthetics a standard beyond ordinary consumer products and graphics.’” Ex. 2109 ¶ 73 (purporting to quote a website affiliated with The Chicago Athenaeum Museum of Architecture and Design). Dr. Grabowski also states that “Christian K. Narkiewicz-Laine, President of the Chicago Athenaeum Museum of Architecture and Design noted that ‘SoloSTAR[®] represents a design for social good and for humanitarian concerns.’” *Id.* Petitioner correctly argues that Exhibit 2201, upon which Patent Owner relies, does not attribute any award to “inventiveness,” and we further note that Exhibit 2201 provides no explanation for how or why an award was given to SoloSTAR[®]. *See* Pet. Reply 25.

Dr. Grabowski also states that “the Lantus[®] and Apidra[®] SoloSTAR[®] devices were put into the permanent Design Collection of the Chicago Athenaeum Museum of Architecture and Design, as recognition of its inventiveness.” Ex. 2109 ¶ 73. Dr. McDuff explains that the document Dr. Grabowski cites in support of his contention that SoloSTAR[®] was placed in the permanent Design Collection of the Chicago Athenaeum Museum of Architecture and Design (*see* Ex. 2109 ¶ 73 n.95) is a DCA press release that does not state that this placement resulted from “recognition of its

inventiveness” and contains no statements attributed to the Chicago Athenaeum. Ex. 1060 ¶ 59.

Third, Patent Owner submits that “at the Prix Galien USA 2009 Award, which ‘recognize[s] innovative biopharmaceutical drugs and medical technologies’ and ‘is considered the industry’s highest accolade for pharmaceutical research and development — equivalent to the Nobel Prize,’ Sanofi and DCA were both finalists.” PO Resp. 49 (citing Ex. 2109 ¶ 74). Patent Owner offers no further explanation of how this constitutes industry praise, but asserts without citation that “Patent Owner did not make up the SoloSTAR[®] awards or bestow upon itself industry praise.” PO Sur-reply 23.

Patent Owner’s evidence of industry praise appears to be directed to SoloSTAR[®], and not Lantus[®] SoloSTAR[®]. Because Patent Owner shows sufficiently that SoloSTAR[®] practices Challenged Claims, Patent Owner would be entitled to a presumption of nexus if Patent Owner shows that SoloSTAR[®] “embodies the claimed features, and is coextensive with them.” *Fox Factory*, 944 F.3d at 1373 (internal quotations omitted). Patent Owner does not argue SoloSTAR[®] is coextensive with any of the Challenged Claims. For example, the case study of SoloSTAR[®] Patent Owner relies upon to show industry praise states that an “important breakthrough” was the combination of “very low injection force . . . with 80 units maximum dose capability.” Ex. 2121, 3; *see also id.* at 5 (emphasizing the attention given to “visual design” during the development of SoloSTAR[®] and asserting that it provides “a total of five differentiation features for improved safety: body colour, dial colour, button colour, label design and a tactile feature on the injection button”). None of the Challenged Claims require any maximum dose capability or “differentiation features.” As with the proffered evidence of long-felt need discussed above, Patent Owner fails to demonstrate nexus

between the purported evidence of industry praise and the claims at issue in this proceeding.

Moreover, even if we assume Patent Owner demonstrates nexus between the alleged industry praise and the claims at issue, much of the praise was generated by DCA, Sanofi's affiliate. *See, e.g.*, Ex. 1055, 76–79. Such self-generated praise is not persuasive industry praise. Further, evidence independent of DCA, such as consideration of Lantus[®] SoloSTAR[®] for the Prix Galien USA 2009 award, only generally specifies the criteria used to judge the nominees. Ex. 2042, 2. It does not evidence industry praise of any specific feature of the claimed invention. *Id.*

c) Commercial Success

Patent Owner contends that the “tremendous commercial success of Lantus[®] SoloSTAR[®] is further objective evidence of non-obviousness.” PO Resp. 49. According to Patent Owner, “commercial success is demonstrated by the contribution of Lantus[®] SoloSTAR[®] to the growth of the Lantus[®] franchise overall,” and by the strong performance of Lantus[®] SoloSTAR[®] when compared to other long-acting insulin and insulin analog pens.” *Id.* at 49–50; *see also id.* at 55–57; PO Sur-reply 19–20.

(1) Patent Owner Fails to Show a Nexus Between the Purported Evidence of Commercial Success and Any Challenged Claim of the '844 Patent

First, Patent Owner fails to show that the asserted evidence of commercial success of Lantus[®] SoloSTAR is a “direct result of the unique characteristics of the claimed invention,” and, therefore, fails to show the necessary nexus. *Fox Factory*, 944 F.3d at 1373–74 (internal quotation omitted). Patent Owner argues that “the features of the device disclosed and claimed in the 844 Patent and used in Lantus[®] SoloSTAR[®] contributed to its

commercial success.” PO Resp. 51 (citing Ex. 2109 ¶ 53; Ex. 2107 ¶¶ 551–610, 651); *see also* PO Sur-reply 20 (asserting that the commercial success of Lantus[®] SoloSTAR[®] “is due at least in part to the elegant features that the challenged claims enable, such as low injection force”). Specifically, Patent Owner argues that SoloSTAR[®] satisfied a long-felt but unfulfilled need for an easy-to-use pen device with low injection force. PO Resp. 51; *see also id.* at 53 (arguing that “[t]he tremendous success of Lantus[®] SoloSTAR[®], as compared to pens with long-acting insulins that failed to address the long-felt but unfilled need for a low injection force device, therefore shares a strong nexus with the claimed invention.”).

Patent Owner does not show that the alleged “tremendous success” may fairly be attributed to the claimed invention, which does not require low injection force or insulin, let alone the long-acting insulin formulation of Lantus. Patent Owner’s argument does not show the necessary nexus, and for the reasons provided above, we found no persuasive evidence in support of Patent Owner’s allegations of long felt need. We likewise find unpersuasive Patent Owner’s argument that, because OptiClik[®] also dispensed Lantus, but had a “higher injection force” and “performed significantly worse than SoloSTAR[®]” such that it was discontinued, the “nexus between SoloSTAR[®]’s lower injection force and its commercial success is further confirmed.” PO Sur-reply 20 (citing Ex. 2109 ¶ 19, 35–30; Ex. 2111 ¶ 28). While the parties appear to agree that the OptiClik[®] was an inferior device, Patent Owner’s implication that it was discontinued only due to its higher injection force is not even supported by Patent Owner’s own expert, Dr. Goland, who explained that “Lantus[®] OptiClik[®] was thus a mechanically inferior design to Lantus[®] SoloSTAR[®]” because, in addition to a higher injection force, OptiClik[®] “did not automatically reset after

injection and thus required additional steps by the user prior to its next,” and “was also relatively large, making it less convenient to carry.” Ex. 2111 ¶ 28. Dr. Biggs described OptiClik[®] as “difficult to refill and unreliable about delivering accurate doses,” (citing Ex. 1045, 528, Table 2) and a “truly bad pen,” but noted that “injection force” was not a concern with OptiClik[®] expressed by his patients. Ex. 1048 ¶¶ 42, 49.

Next Patent Owner asserts that “the SoloSTAR[®] device won numerous design awards, and achieved significant industry praise.” PO Resp. 51. Again, Patent Owner’s argument does not show the necessary nexus, and for the reasons provided above, we found no persuasive evidence in support of Patent Owner’s allegations of industry praise. The only remaining arguments Patent Owner makes is that “the SoloSTAR[®] device embodies the challenged claims of the 844 patent,” and “[t]hus, there is a nexus between the claimed invention in the 844 patent and the commercial success of Lantus[®] SoloSTAR[®].” *Id.* Patent Owner is wrong with regard to what must be shown to establish nexus.

There is no dispute that Lantus[®] SoloSTAR[®] is not coextensive with any of the Challenged Claims. Patent Owner relies on Lantus[®] SoloSTAR[®] to show commercial success, but merely showing that SoloSTAR[®] “embodies” any of the Challenged Claims fails to establish the necessary nexus between the evidence of commercial success and any challenged claim. Patent Owner suggests that “the success of SoloSTAR[®] is attributable at least in part to its unique design covered by the 844 patent.” PO Resp. 53. Contrary to Patent Owner’s argument, Patent Owner does not show persuasively that any “feature” purportedly disclosed and claimed in the ’844 patent contributed to the commercial success of Lantus[®] SoloSTAR[®]. To be clear, that does not mean that the design of SoloSTAR[®],

including unclaimed features and aesthetics, was irrelevant to the purported commercial success of Lantus[®] SoloSTAR[®]. Rather, Patent Owner does not show that the asserted evidence of commercial success of Lantus[®] SoloSTAR is a “direct result of the unique characteristics of the claimed invention.”

(2) Patent Owner Fails to Show Commercial Success of Lantus[®] SoloSTAR[®]

Patent Owner argues that the following demonstrate the commercial success Lantus[®] SoloSTAR[®]:

- “fast and long-sustained growth in terms of dollar sales, new prescriptions, and total prescriptions”;
- “the overall levels and shares of dollar sales, new prescriptions, and total prescriptions, as well as the profitability and formulary placement”;
- “sales and prescriptions . . . remained strong despite the entry of several competing long-acting insulin and insulin analog drugs (all in pen form) starting in 2015”;
- “the highest level of sales among long-acting insulin and insulin analog pens even though it launched after several other long-acting insulin and insulin analog pens, including the Levemir[®] FlexPen[®]”;
- “substantial growth relative to Lantus[®] OptiClik[®]” based on new prescriptions and total prescriptions.

PO Resp. 50–51 (citing Ex. 2109 ¶¶ 12, 37). Additionally, Patent Owner contends that marketing does not explain the commercial success because “marketing expenditures for Lantus[®] SoloSTAR[®] were in line with, or were lower than, many other long-acting insulin products.” *Id.* at 52 (citing

Ex. 2109 ¶¶ 16, 64–69). Regarding “alleged ‘blocking patents’ covering the glargine molecule that is used in the production of the active ingredient in Lantus®,” Patent Owner argues that “the law does not mandate across-the-board-discounting of commercial success simply because other patents cover components of the product,” and that the Board should “weigh the evidence on a case-by-case basis, in light of the specific commercial success argument being made.” *Id.* at 52–53. According to Patent Owner, “the success of Lantus® SoloSTAR® cannot be attributed solely to the insulin glargine molecule because Lantus® OptiClik® used the exact same Lantus® formulation” and did not achieve SoloSTAR®’s success, thus the design of SoloSTAR® must have attributed at least in part to the success. *Id.* at 53. Patent Owner further argues that “Sanofi’s earlier patents on the insulin glargine molecule did not prevent others from entering the market for non-glargine, long-acting insulin products and competing with Lantus® SoloSTAR®.” *Id.* Patent Owner identifies Levemir® FlexPen® with its long-acting insulin as an example of a disposable pen device with long-acting insulin. *Id.*

Petitioner disputes Patent Owner’s contentions, arguing, *inter alia*, that Patent Owner does not address profitability and “provides no benchmarks for evaluating success, applies a faulty ‘pens-only’ market definition, and [that] formulary status does not separately demonstrate commercial success.” Pet. Reply 25–26 (citing Ex. 1048 ¶¶ 17–28). Petitioner also argues that “Lantus® SoloSTAR® enjoyed the benefit of a Lantus® franchise that predated the Levemir® franchise by five years and the foundation of earlier Lantus® pen (OptiClik®),” which had “twice as many prescriptions in 2007 as Levemir® FlexPen®.” Pet. Reply 26–27 (citing Ex. 2186, 2; Ex. 2198). Petitioner contends that “Lantus® SoloSTAR®

overtook Levemir[®] FlexPen[®] not because of any unique SoloSTAR[®] attributes,” but because Patent Owner “selected it as the exclusive Lantus[®] pen in the United States.” *Id.* at 27 (citing Ex. 1075 ¶¶ 20–22, 30–35).

Patent Owner replies that Petitioner’s own data shows that Lantus[®] SoloSTAR[®] has been commercially successful (citing Ex. 1060, Attachment B-10; Ex. 2318, 31:14–17, 31:25–32:8), that the diabetes community has widely adopted Lantus[®] SoloSTAR[®]; that Dr. McDuff acknowledged the large Lantus[®] SoloSTAR[®] sales and admitted that profitability analysis is not required (citing Ex. 2318, 15:10–13, 28:7–19, 29:20–30:18), and that Lantus[®] SoloSTAR[®] has the largest market share in Petitioner’s asserted broader market (citing Ex. 1060, Attachment B-10; Ex. 2318, 31:14–17, 31:25–32:8). PO Sur-reply 17–18. Patent Owner further contends that Lantus[®] SoloSTAR[®] prescriptions more than quadrupled that of OptiClik[®] in the first four years of each product’s respective launch and that Lantus[®] SoloSTAR[®] grew the Lantus[®] market and remains the number one product. *Id.* at 18 (citing Ex. 1060, Attachment B-10; Ex. 2318, 18:23–19:20, 21:22–22:8). Patent Owner asserts that “SoloSTAR[®] enjoys favorable placement in health,” due, in part as admitted by Dr. McDuff, to its “mechanical features and attributes.” *Id.* at 18 (citing Ex. 2318, 33:7–36:3).

Having considered all of the evidence of commercial success presented by the parties, we find that the data presented in Attachment B-10 of Exhibit 1060 to be the most pertinent evidence regarding the purported commercial success of Lantus[®] SoloSTAR[®] provided in this proceeding. Attachment B-10 presents total prescription data by year for 40 insulin delivery products for the 20-year period 1999–2019. Ex. 1060, Attachment B-10. It also provides corresponding market share data for that same time period. *Id.*

Attachment B-10 shows that from the introduction of Lantus[®] Vial in 2002, until 2019, Lantus[®] delivery products (i.e., Lantus[®] Vial, Lantus[®] OptiClik[®], and Lantus[®] SoloSTAR[®]) were by far the most proscribed insulin delivery devices. Ex. 1060, Attachment B-10. As shown, from 2002 to 2011 prescriptions of Lantus[®] Vial grew from roughly 1.3 to 11 million prescriptions, while the most successful competing products (Humulin and Novolog) each grew to prescription levels of roughly 5 million prescriptions. *Id.* Thus, Attachment B-10 clearly demonstrates the commercial success of Lantus[®] Vial during that time period. Attachment B-10 also demonstrates that once Lantus[®] OptiClik[®] was introduced, prescriptions of Lantus[®] Vial decreased as prescriptions of Lantus[®] OptiClik[®] increased, with the overall number of Lantus[®] OptiClik[®] prescriptions slowly, but steadily climbing. *Id.* We note that during the time period that Lantus[®] OptiClik[®] was the only Lantus[®] alternative to Lantus[®] Vial, the number of Lantus[®] Vial prescriptions essentially stayed the same.

In 2008, Lantus[®] SoloSTAR[®] was introduced. Ex. 1060, Attachment B-10. From 2008–2011, prescriptions of Lantus[®] SoloSTAR[®] steadily rose while prescriptions of Lantus[®] OptiClik[®] declined. *Id.* During this time period, prescriptions of Lantus[®] Vial continued to remain steady. *Id.* Then in 2012, things changed. *Id.* First, prescriptions of Lantus[®] OptiClik[®] dropped off significantly. *Id.* By 2014, prescriptions of Lantus[®] OptiClik[®] dropped to a mere 382 prescriptions. *Id.* During the time period from 2011–2016 (when prescriptions of Lantus[®] SoloSTAR[®] hit their peak), prescriptions of Lantus[®] Vial began to decrease at a rate of about 500,000 prescriptions per year. It is unknown why prescriptions of Lantus[®] Vial began to decline starting in 2012, but it appears that they declined as the prescriptions of Lantus[®] SoloSTAR[®] increased. Regardless of the reason for

the decline, the evidence clearly shows that the number of Lantus[®] SoloSTAR[®] prescriptions peaked in 2016 and that most of the increase in prescriptions for Lantus[®] SoloSTAR[®] merely offset the decline in prescriptions for Lantus[®] Vial. Thus, the evidence does not support a showing of commercial success for Lantus[®] SoloSTAR[®]. Rather, it appears to show a fairly stable number of prescriptions for Lantus[®] products from 2009–2016, with a decline in those prescriptions from 2017–2019.

6. Collective Consideration of the Graham Factors

Having considered each of the *Graham* factors individually, we now consider them collectively. The scope and content of the prior art, the differences between the prior art and claims 21–29 of the '844 patent, and the level of ordinary skill in the art heavily favor Petitioner's contention that claims 21–29 would have been obvious over Steinfeldt-Jensen. Petitioner also provides a persuasive rationale in support of the asserted modification of the fifth embodiment of Steinfeldt-Jensen.

Having considered all the evidence of indicia of nonobviousness, Patent Owner does not show the requisite nexus between the alleged objective indicia of nonobviousness and the Challenged Claims of the '844 patent. Moreover, even if Patent Owner had shown nexus, the objective evidence of nonobviousness identified by Patent Owner fails to show persuasive evidence of a long-felt, unmet need satisfied by the invention of any of the Challenged Claims. Patent Owner also fails to show persuasive evidence of either industry praise of SoloSTAR[®] or of commercial success of Lantus[®] SoloSTAR[®]. Thus, Patent Owner's evidence of indicia of nonobviousness provides very little, if any, support for nonobviousness of the Challenged Claims.

On the whole, we find that the information provided by Petitioner and Patent Owner in consideration of the *Graham* factors collectively demonstrates by a preponderance of the evidence that the subject matter of claims 21–29 of the ’844 patent would have been obvious over Steinfeldt-Jensen.

F. Alleged Obviousness Over Steinfeldt-Jensen and Klitgaard

Petitioner contends that claim 30 of the ’844 patent would have been obvious over the combination of Steinfeldt-Jensen and Klitgaard. Pet. 69–71; Pet. Reply 1. Claim 30 depends from claim 21 and further recites “a nut that tracks each set dose of medicament delivered.” Ex. 1004, 9:8–10. Petitioner relies on its analysis of claim 21 to support its contention that claim 30 would have been obvious over the combination of Steinfeldt-Jensen and Klitgaard. Pet. 69. Patent Owner argues that Petitioner fails to show that claim 30 would have been obvious over the combination of Steinfeldt-Jensen and Klitgaard “for the same reasons” that Patent Owner argues Petitioner does not show claim 21 would have been obvious over Steinfeldt-Jensen. PO Resp. 41; PO Sur-reply 1–2. In other words, Patent Owner makes no argument in opposition to Petitioner’s contentions with regard to claim 30 beyond the arguments addressed above that Patent Owner asserted against the alleged obviousness of claim 21, from which claim 30 depends. For the reasons provided above, Petitioner shows by a preponderance of the evidence that claim 21 would have been obvious over Steinfeldt-Jensen. Despite the absence of any additional arguments from Patent Owner directed to claim 30, we nevertheless we must consider whether Petitioner shows by a preponderance of the evidence that claim 30 would have been obvious over Steinfeldt-Jensen and Klitgaard.

1. *Differences Between the Subject Matter of Claim 30 and the Teachings of Steinfeldt-Jensen and Klitgaard*

Petitioner relies on Klitgaard as teaching the limitation of claim 30 and on Steinfeldt-Jensen as teaching the limitations of claim 21 from which claim 30 depends. Pet. 69–72. As explained above, Petitioner shows and Patent Owner does not dispute that Steinfeldt-Jensen teaches or suggests every limitation of claim 21. Petitioner also shows that Klitgaard teaches an injection device with nut member 32 that, “[d]uring the setting of a dose” rotates “with the does setting member 30 relative to the driver 31 so that the position of the nut member 32 on this driver is dependent on the dose set.” Pet. 70 (quoting Ex. 1017, 4:33–37). The injector of Klitgaard operates such that “the nut member 32 on the driver 31 will always indicate the total sum of set and injected doses.” *Id.* (quoting Ex. 1017, 4:52–54). Accordingly, Petitioner shows by a preponderance of the evidence that Klitgaard teaches nut member 32 corresponding to “a nut that tracks each set dose of medicament delivered,” as required by claim 30, and that the combination of Steinfeldt-Jensen and Klitgaard teaches or suggests every limitation of claim 30.

2. *Reasons for the Combination of Steinfeldt-Jensen and Klitgaard*

Petitioner shows that a person of ordinary skill in the art would have had a reasonable expectation of success in incorporating nut member 32 of Klitgaard into the Steinfeldt-Jensen syringe, because the nut “could be readily adapted and disposed between the bushing 82 and scale drum 80 [of Steinfeldt-Jensen] to track each set dose of medicament delivered.” Pet. 71 (citing Ex. 1011 ¶ 692). Petitioner relies on Klitgaard’s explanation that the nut indicates “the total sum of set and injected doses” and prevents “setting a dose that exceeds the remaining available supply of medication in the

cartridge” as the reasons a person of ordinary skill in the art would have modified Steinfeldt-Jensen. *Id.* (citing Ex. 1017, 4:52–58, Abstract). The uncontested reasons Petitioner shows for the asserted combination establishes a legally sufficient rationale in support of the combination.

3. *Objective Indicia of Nonobviousness*

Patent Owner relies on the same evidence of objective indicia of nonobviousness as discussed above with regard to the asserted obviousness of claim 21 over Steinfeldt-Jensen.

4. *Collective Consideration of the Graham Factors*

With regard to claim 30 of the ’844 patent, having considered each of the *Graham* factors individually, we now consider them collectively. The scope and content of the prior art, the differences between the prior art and claim 30, and the level of ordinary skill in the art heavily favor Petitioner’s contention that claim 30 would have been obvious over the combination of Steinfeldt-Jensen and Klitgaard. Petitioner shows by a preponderance of the evidence that the combination of Steinfeldt-Jensen and Klitgaard teaches every limitation of claim 30. Petitioner’s reliance on Klitgaard’s explanation that the nut indicates the total sum of set and injected doses and prevents setting a dose that exceeds the remaining available supply of medication in the cartridge provides a persuasive rationale for why a person of ordinary skill in the art would have modified Steinfeldt-Jensen to obtain the benefits of the nut taught by Klitgaard. *See* Ex. 1017, 4:52–58.

Additionally, as explained in detail above, having considered all the evidence of indicia of nonobviousness, Patent Owner does not show the requisite nexus between the alleged objective indicia of nonobviousness and the Challenged Claims of the ’844 patent. Moreover, even if Patent Owner had shown nexus, the objective evidence of nonobviousness identified by

Patent Owner fails to show persuasive evidence of a long-felt, unmet need satisfied by the invention of any of the Challenged Claims. Patent Owner also fails to show persuasive evidence of either industry praise of SoloSTAR[®] or of commercial success of Lantus[®] SoloSTAR[®]. Thus, Patent Owner's evidence of indicia of nonobviousness provides very little, if any, support for nonobviousness of claim 30.

On the whole, we find that the information provided by Petitioner and Patent Owner in consideration of the *Graham* factors collectively demonstrates by a preponderance of the evidence that the subject matter of claim 30 of the '844 patent would have been obvious over the combination of Steinfeldt-Jensen and Klitgaard.

III. ANALYSIS OF PATENT OWNER'S CORRECTED REVISED CONTINGENT MOTION TO AMEND

Patent Owner's Corrected Revised Contingent Motion to Amend seeks entry of substitute claims 31–38 to the extent that we find the Challenged Claims unpatentable. RMTA 1–2. As discussed above, Petitioner shows by a preponderance of the evidence that the Challenged Claims are unpatentable. We now turn to consider whether to enter any of the substitute claims proposed by Patent Owner. For the reasons that follow, we deny Patent Owner's motion because the substitute claims it proposes lack written description support, as required by 35 U.S.C. § 316(d) and 37 C.F.R. § 42.121.

A. Principles of Law Concerning a Motion to Amend

In an *inter partes* review, amended claims are not added to a patent as of right, but rather must be proposed as a part of a motion to amend. 35 U.S.C. § 316(d). The Board must assess the patentability of proposed substitute claims “without placing the burden of persuasion on the patent

owner.” *Aqua Prods., Inc. v. Matal*, 872 F.3d 1290, 1328 (Fed. Cir. 2017) (en banc); see also *Lectrosonics, Inc. v. Zaxcom, Inc.*, IPR2018-01129, Paper 15 at 3–4 (PTAB Feb. 25, 2019) (precedential). Subsequent to the issuance of *Aqua Products*, the Federal Circuit issued a decision in *Bosch Automotive Service Solutions, LLC v. Matal*, 878 F.3d 1027 (Fed. Cir. 2017) (“*Bosch*”), as well as a follow-up order amending that decision on rehearing. See *Bosch Auto. Serv. Sols., LLC v. Iancu*, No. 2015-1928 (Fed. Cir. Mar. 15, 2018) (Order on Petition for Panel Rehearing).

In accordance with *Aqua Products*, *Bosch*, and *Lectrosonics*, a patent owner does not bear the burden of persuasion to demonstrate the patentability of the substitute claims presented in the motion to amend. Rather, ordinarily, “the petitioner bears the burden of proving that the proposed amended claims are unpatentable by a preponderance of the evidence.” *Bosch*, 878 F.3d at 1040 (as amended on rehearing); *Lectrosonics*, Paper 15 at 3–4. In determining whether a petitioner has proven unpatentability of the substitute claims, the Board focuses on “arguments and theories raised by the petitioner in its petition or opposition to the motion to amend.” *Nike, Inc. v. Adidas AG*, No. 2019-1262, 2020 WL 1802796, at *5 (Fed. Cir. Apr. 9, 2020). The Board itself also may justify any finding of unpatentability by reference to evidence of record in the proceeding. *Lectrosonics*, Paper 15 at 4 (citing *Aqua Products*, 872 F.3d at 1311 (O’Malley, J.)).

“Before considering the patentability of any substitute claims” we “first must determine whether the motion to amend meets the statutory and regulatory requirements set forth in 35 U.S.C. § 316(d) and 37 C.F.R. § 42.121.” *Lectrosonics*, Paper 15 at 4. Accordingly, a patent owner must demonstrate: (1) the amendment proposes a reasonable number of substitute

claims; (2) the proposed claims are supported in the original disclosure (and any earlier filed disclosure for which the benefit of filing date is sought); (3) the amendment responds to a ground of unpatentability involved in the trial; and (4) the amendment does not seek to enlarge the scope of the claims of the patent or introduce new subject matter. *See* 35 U.S.C. § 316(d); 37 C.F.R. § 42.121.

B. Substitute Claims 31–38

Patent Owner submits substitute claims 31–38, set forth below, with additions to the original claim shown in underlining and deletions shown in brackets or strikethroughs.¹³ Substitute claim 31 is independent. Substitute claims 32, 35, and 36 depend from substitute claim 31. Substitute claims 33, 37, and 38 depend from original claim 21, and substitute claim 34 depends from substitute claim 33.

1. Substitute claim 31 (to replace claim 21)

31. A drug delivery device comprising:
a housing comprising a dose dispensing end and a first thread;
a dose indicator comprising a second thread that engages with
the first thread;
a driving member comprising a third thread;
a sleeve that is (i) disposed between the dose indicator and the
driving member and (ii) releasably connected to the dose
indicator;

¹³ Patent Owner provides its substitute claims in Appendix A to its Revised Contingent Motion to Amend (Paper 64, App. A (“Claims Appendix”)), but did not provide such an appendix of substitute claims with its subsequent Corrected Revised Contingent Motion to Amend (Paper 71). Patent Owner confirmed that references to a claims appendix in the Corrected Revised Contingent Motion to Amend are intended to refer to the claims appendix provided with the earlier filed Revised Contingent Motion to Amend. Ex. 1110, 17:14–19:17. We, therefore, rely on and refer to the same earlier-filed claims appendix.

- a piston rod comprising ~~either an internal or an external~~ a fourth thread that is engaged with the third thread;
- a piston rod holder that is rotatably fixed relative to the housing and configured to (i) prevent the piston rod from rotating during dose setting and (ii) permit the piston rod to traverse axially towards the distal end during dose dispensing; wherein:
 - the housing is disposed at an outermost position of the drug delivery device;
 - the dose indicator is disposed between the housing and the sleeve and is configured to (i) rotate and traverse axially away from the dose dispensing end during dose setting and (ii) rotate and traverse axially towards the dose dispensing end during dose dispensing;
 - the driving member is configured to rotate relative to the piston rod;
 - the sleeve is rotatably fixed relative to the driving member and configured to traverse axially with the dose indicator; and
 - the piston rod and the driving member are configured to rotate relative to one another during dose dispensing; and
 - the piston rod is configured to traverse axially towards the dose dispensing end during dose dispensing.

Claims Appendix 1–2.

2. *Substitute claim 32 (to replace claim 23)*

32. The drug delivery device of claim ~~[[21]]~~ 31 wherein the sleeve further comprising is a clutch;
wherein the drug delivery device has only one arc shaped body that is both within the housing and configured to track each set dose of medicament as said dose indicator is rotated relative to the arc shaped body, the arc shaped body comprising proximal and distal surfaces, end-most side surfaces, and inner and outer curved surfaces, the end-most side surfaces being circumferentially spaced apart, one of the curved surfaces comprising a fifth thread that is engaged with a sixth thread, and wherein the arc shaped body is configured

to (i) during dose setting, move axially relative to the housing without rotating relative to the housing, and (ii) abut a radial stop when at a final dose position, said radial stop disposed separate from the sixth thread;

wherein said drug delivery device further comprises:

a first clicker feature comprising teeth configured to provide audible clicks (i) by dragging the teeth over corresponding teeth on said clutch and (ii) only during dialing down of a dose without dispensing medicament, where each click relates to a unit dose of medicament; and

a second clicker feature spaced axially apart from the first clicker feature and disposed adjacent an end of the dose indicator that is nearest the dose dispensing end, the second clicker feature comprising a flexible arm configured (i) to move axially relative to splines in only a first axial direction during dialing up of a dose and to move axially relative to the splines in only a second, opposite, axial direction during dose dispensing and (ii) to provide audible clicks by dragging a tooth member over the splines while rotating and moving axially relative to the splines; and

a zero dose stop on the housing, wherein the zero dose stop protrudes radially inward and prevents the dose indicator from rotating in a dialing down direction past an end position.

Id. at 2–3.

3. *Substitute claim 33 (to replace claim 24)*

33. The drug delivery device of claim [[23]] 21

wherein the sleeve is a clutch;

wherein the device comprises a first clicker feature with teeth configured to provide audible clicks by dragging the teeth over corresponding teeth on the clutch and provide[[s]] audible and tactile feedback only during dose correction that is indicative of unit doses of medicament; and

wherein the device comprises a second clicker feature spaced axially apart from the first clicker feature and disposed

adjacent an end of the dose indicator that is nearest the dose dispensing end, the second clicker feature comprising a flexible arm configured (i) to move axially relative to splines in only a first axial direction during dialing up of a dose and move axially relative to the splines in only a second, opposite, axial direction during dose dispensing and (ii) to provide audible clicks by dragging a tooth member over the splines while rotating and moving axially relative to the splines.

Id. at 3.

4. *Substitute claim 34 (to replace claim 26)*

34. The drug delivery device of claim [[24]] 33

wherein the clutch allows the dose cancelling without dispensing medicament; and

wherein the drug delivery device has only one arc shaped body that is both within the housing and configured to track each set dose of medicament as said dose indicator is rotated relative to the arc shaped body, the arc shaped body comprising proximal and distal surfaces, end-most side surfaces, and inner and outer curved surfaces, the end-most side surfaces being circumferentially spaced apart, one of the curved surfaces comprising a fifth thread that is engaged with a sixth thread, and wherein the arc shaped body is configured to (i) during dose setting, move axially relative to the housing without rotating relative to the housing, and (ii) about a radial stop when at a final dose position, said radial stop disposed separate from the sixth thread.

Id. at 3–4.

5. *Substitute claim 35 (to replace claim 27)*

35. The drug delivery device of claim [[24]] 31

wherein the sleeve is a clutch; and

the drug delivery device further comprising a button seated in an annular recess of a dose dial grip on a proximal end of the dose indicator, where the button is rotatable relative to the dose indicator[.];

a first clicker feature comprising teeth configured to provide audible and tactile feedback (i) by dragging the teeth over corresponding teeth on said clutch and (ii) only during dialing down of a dose without dispensing medicament, the feedback being indicative of unit doses of medicament; and

a second clicker feature spaced axially apart from the first clicker feature and disposed adjacent an end of the dose indicator that is nearest the dose dispensing end, the second clicker feature comprising a flexible arm configured (i) to move axially relative to splines in only a first axial direction during dialing up of a dose and to move axially relative to the splines in only a second, opposite, axial direction during dose dispensing and (ii) to provide audible clicks by dragging a tooth member over the splines while rotating and moving axially relative to the splines.

Id. at 4–5.

6. *Substitute claim 36 (to replace claim 29)*

36. The drug delivery device of claim [[21]] 31

further comprising a clicker that provides audible clicks during dose setting, where each click is equal to a unit dose of medicament, wherein said clicker comprises:

a flexible arm extending from a fixed end circumferentially to a free end thereof, the flexible arm comprising a tooth on the free end, the flexible arm configured to: (i) provide audible clicks while rotationally fixed relative to the sleeve, which is a clutch, and while the clicker is moving axially relative to the housing in a first direction during dialing up of a dose, where each click relates to a unit dose of the medicament, and (ii) not provide audible clicks while the clicker is moving axially relative to the housing in a second, opposite, direction during dialing down of a dose without dispensing the medicament; and

one-way teeth configured to: (i) provide audible clicks by dragging over corresponding teeth of the clutch while the clicker is moving axially relative to the housing in the second direction during dialing down of a dose without

dispensing the medicament, where each click relates to a unit dose of the medicament and, (ii) not provide audible clicks while the clicker is moving axially relative to the housing in the first direction during dialing up of a dose; and

wherein the drug delivery device has only one arc shaped body that is both within the housing and configured to track each set dose of medicament as said dose indicator is rotated relative to the arc shaped body, the arc shaped body comprising proximal and distal surfaces, end-most side surfaces, and inner and outer curved surfaces, the end-most side surfaces being circumferentially spaced apart, one of the curved surfaces comprising a fifth thread that is engaged with a sixth thread, and wherein the arc shaped body is configured to (i) during dose setting, move axially relative to the housing without rotating relative to the housing, and (ii) abut a radial stop when at a final dose position, said radial stop disposed separate from the sixth thread.

Id. at 5–6.

7. *Substitute claim 37 (to replace claim 29)*

37. The drug delivery device of claim 21

further comprising a clicker that provides audible clicks during dose setting, where each click is equal to a unit dose of medicament, wherein said clicker comprises:

a flexible arm extending from a fixed end, circumferentially to a free end thereof, the flexible arm comprising a tooth on the free end, the flexible arm configured to: (i) provide audible clicks while rotationally fixed relative to the sleeve, which is a clutch, and while the clicker is moving axially relative to the housing in a first direction during dialing up of a dose, where each click relates to a unit dose of the medicament, and (ii) not provide audible clicks while the clicker is moving axially relative to the housing in a second, opposite, direction during dialing down of a dose without dispensing the medicament; and

one-way teeth configured to: (i) provide audible clicks by dragging over corresponding teeth of the clutch while the clicker is moving axially relative to the housing in the second direction during dialing down of a dose without dispensing the medicament, where each click relates to a unit dose of the medicament and, (ii) not provide audible clicks while the clicker is moving axially relative to the housing in the first direction during dialing up of a dose; and

wherein the drug delivery device has only one arc shaped body that is both within the housing and configured to track each set dose of medicament as said dose indicator is rotated relative to the arc shaped body, the arc shaped body comprising proximal and distal surfaces, end-most side surfaces, and inner and outer curved surfaces, the end-most side surfaces being circumferentially spaced apart, one of the curved surfaces comprising a fifth thread that is engaged with a sixth thread, and wherein the arc shaped body is configured to (i) during dose setting, move axially relative to the housing without rotating relative to the housing, and (ii) abut a radial stop when at a final dose position, said radial stop disposed separate from the sixth thread.

Id. at 6–7.

8. *Substitute claim 38 (to replace claim 30)*

38. The drug delivery device of claim 21 further comprises comprising:

a nut that tracks each set dose of medicament delivered; and a clicker that provides audible clicks during dose setting, where each click relates to a unit dose of medicament, wherein said clicker comprises:

a flexible arm extending from a fixed end, circumferentially to a free end thereof, the flexible arm comprising a tooth on the free end, the flexible arm configured to: (i) provide audible clicks while rotationally fixed relative to the sleeve, which is a clutch, and while the clicker is moving axially relative to the housing in a first direction during dialing up

of a dose, where each click relates to a unit dose of the medicament, and (ii) not provide audible clicks while the clicker is moving axially relative to the housing in a second, opposite, direction during dialing down of a dose without dispensing the medicament; and

one-way teeth configured to: (i) provide audible clicks by dragging over corresponding teeth of the clutch while the clicker is moving axially relative to the housing in the second direction during dialing down of a dose without dispensing the medicament, where each click relates to a unit dose of the medicament and, (ii) not provide audible clicks while the clicker is moving axially relative to the housing in the first direction during dialing up of a dose.

Id. at 7–8.

C. Written Description and New Matter Under 35 U.S.C. § 316(d)(3) and 37 C.F.R. § 42.121(a)(2)(ii) and (b)

An amendment may not enlarge the scope of the claims of the patent or introduce new matter. 35 U.S.C. § 316(d)(3); 37 C.F.R. § 42.121(a)(2)(ii). In connection with its motion to amend, a patent owner must set forth “support in the original disclosure of the patent for each claim that is added or amended,” and “support in an earlier-filed disclosure for each claim for which benefit of the filing date of the earlier filed disclosure is sought.” 37 C.F.R. § 42.121(b). Patent Owner’s motion fails to set forth adequate written description support for the proposed substitute claims.

1. Principles of Law Regarding Written Description

When a priority claim involves a chain of priority documents, “each application in the chain leading back to the earlier application must comply with the written description requirement of 35 U.S.C. § 112.” *Lockwood v. Am. Airlines, Inc.*, 107 F.3d 1565, 1571 (Fed. Cir. 1997). The test for determining compliance with the written description requirement entails “an objective inquiry into the four corners of the specification from the

perspective of a person of ordinary skill in the art,” and, “[b]ased on that inquiry, the specification must describe an invention understandable to that skilled artisan and show that the inventor actually invented the invention claimed.” *Ariad Pharm., Inc. v. Eli Lilly & Co.*, 598 F.3d 1336, 1351 (Fed. Cir. 2010) (en banc). As the Federal Circuit has noted, however, “[i]n order to satisfy the written description requirement, the disclosure as originally filed does not have to provide *in haec verba* support for the claimed subject matter at issue.” *Purdue Pharma L.P. v. Faulding Inc.*, 230 F.3d 1320, 1323 (Fed. Cir. 2000). Rather, “the test for sufficiency is whether the disclosure of the application relied upon reasonably conveys to those skilled in the art that the inventor had possession of the claimed subject matter as of the filing date.” *Ariad*, 598 F.3d at 1351. “The level of detail required to satisfy the written description requirement varies depending on the nature and scope of the claims and on the complexity and predictability of the relevant technology.” *Id.* A lower level of detail is required to satisfy the written description requirement in cases, such as this, where the field of the invention, a mechanical device, is a predictable art. *See Hologic, Inc. v. Smith & Nephew, Inc.*, 884 F.3d 1357, 1361 (Fed. Cir. 2018). However, “[i]t is not sufficient for purposes of the written description requirement of § 112 that the disclosure, when combined with the knowledge in the art, would lead one to speculate as to modifications that the inventor might have envisioned, but failed to disclose.” *Lockwood*, 107 F.3d at 1572.

2. *Patent Owner Does Not Show Sufficient Written Description Support for Substitute Claims 31–38*

Patent Owner contends substitute claims 31–38 are fully supported by the original disclosure of the ’616 application and “the line of priority documents noted on the face of the ’844 Patent, which extend back to” the

GB application. RMTA 5; *see also* Ex. 2304; Ex. 2313. In support of its contentions, Patent Owner provides a table of pin citations to the '616 application and the GB application, pin citations to Dr. Slocum's declaration (Ex. 2302), which purportedly provides "explanatory analysis of certain disclosures" from the perspective of a person of ordinary skill in the art, and additional discussion of certain features of the substitute claims. RMTA 5–18.

Petitioner argues that Patent Owner does not sufficiently identify written description support for each substitute claim, because Patent Owner provides "analysis for only a few limitations" and otherwise relies on "a table of citation without analysis."¹⁴ RMTA Opp. 1. More specifically, Petitioner contends four limitations lack support. RMTA Opp. 2–8. We address only one of the four limitations addressed by Petitioner, because we find it dispositive of the motion, reproduced below as originally provided in claim 21 and as proposed in substitute claim 31:

¹⁴ Petitioner notes that the restriction on grounds of unpatentability that may be raised to challenge issued claims in an *inter partes* review under § 311(b) does not "limit the grounds of unpatentability that can be raised in response to proposed substitute claims presented in a motion to amend." RMTA Opp. 2 n.1 (quoting *Amazon.com, Inc. v. Uniloc Luxembourg S.A.*, IPR2017-00948, Paper 34 at 5 (PTAB Jan. 18, 2019) (precedential)).

Claim 21: “a driving member comprising a third thread” and “a piston rod comprising either an internal or an external fourth thread that is engaged with the third thread”

Substitute Claim 31: “a driving member comprising a third thread” and “a piston rod comprising a fourth thread that is engaged with the third thread”

Patent Owner proposes substitute claim 31 as an amendment of challenged claim 21. Challenged claim 21 recites “a driving member comprising a third thread” and “a piston rod comprising *either an internal or an external* fourth thread that is engaged with the third thread.” Ex. 1004, 8:36–49 (emphasis added). Patent Owner proposes amending claim 21 by deleting the phrase “either an internal or an external,” whereby substitute claim 31 then recites “a piston rod comprising *a* fourth thread that is engaged with the third thread.” Claims Appendix 1 (Element 31[e]) (emphasis added to show “a” was added to substitute claim 31). Patent Owner proposes no other amendments to claim 21. Thus, substitute claim 31 is identical to challenged claim 21, but for the *omission* of “either an internal or an external” from claim 21 (and the addition to substitute claim 31 of “a” prior to “fourth thread”). *See* RMTA 3.

In IPR2018-01680, we are issuing, contemporaneously, a final written decision in which we determine that Petitioner demonstrates that the Challenged Claims are not entitled to a priority date prior to May 17, 2016, the filing date of the ’616 application, because the GB application does not provide written description support for a “piston rod comprising . . . an internal . . . fourth thread” (i.e., an internally threaded piston rod), as recited in claim 21, claim 21 was not entitled to priority to the GB application. *See also* Ex. 1026, 2:1–5, 5:19–27, 11:9–11, Figs. 1–7, 9–13 (showing that the

GB application discloses an externally threaded piston rod, but not an internally threaded piston rod or a genus of threaded piston rods). As a result, we further find in IPR2018-01680 that Giambattista is prior art to claim 21, and that Petitioner shows that Giambattista anticipates claim 21.

In discussing substitute claim 31, Patent Owner begins by seeking “to be clear at the outset” that the written description analysis of claim 21 “does not dictate the outcome for *amended* claim 31,” because substitute claim 31 “is different” and there is no requirement for written description support of “an un-recited feature.” RMTA 8–9. We emphasize, again, that the only claim language that is “different” between claim 21 and substitute claim 31 is the omission of “either an internal or an external” from claim 21 (and the addition of “a”). Claims Appendix 1 (Element 31[e]). We agree with Patent Owner that an analysis of written description support for claim 21 does not “dictate” the same outcome with respect to substitute claim 31.

Patent Owner further maintains that by manipulating the language of claim 21 to eliminate any specific reference to either “an internal” or “an external” fourth thread in substitute claim 31, Patent Owner can: (1) have the scope of substitute claim 31 be *identical* to the scope of claim 21, and (2) “eliminate[] Giambattista from consideration as a prior art reference” to substitute claim 31, because a lack of written description for an internally threaded piston rod is purportedly no longer an issue. RMTA 3, 18–19. Patent Owner further asserts that “while the test for written description support of claim 21 requires possession of both external and internal threads, for [substitute] claim 31, the test only requires possession of a thread.” PO Sur-reply 3–4. We disagree with Patent Owner that possession by the inventors of “a thread” provides sufficient written description to support substitute claim 31 with a scope identical to claim 21, which, as explained

above, is an unpatentable claim. *See supra* § II.E. Indeed, Patent Owner recognizes that a “proper written description inquiry” is focused on “whether ‘the four corners of the specification’ demonstrate ‘the inventor actually invented the invention claimed.’” RMTA 9 (quoting *Ariad Pharm.*, 598 F.3d at 1351). The “four corners” of the GB application make clear that Patent Owner did not invent what Patent Owner now seeks to claim in substitute claim 31, for the reasons provided below.

The error in Patent Owner’s argument that it need show no more than possession of a “thread” turns on the fact that the GB application discloses only an externally threaded piston rod, not an internally threaded piston rod. A preponderance of the evidence further shows that the GB application, in light of the knowledge of a person of ordinary skill in the art, does not disclose or suggest any alternative to an externally threaded piston, much less that the internally threaded piston rod, as applied in the GB application, was but a member of a “genus” of threaded piston rods with well-known, interchangeable options, as explained below. To the contrary, there is no disclosure or suggestion in the GB application that an internally threaded piston rod would be functional in light of the required arrangement of other features of the pen injector disclosed. *See generally* Ex. 1026.

To the extent that Patent Owner seeks through substitute claim 31 to claim all threaded piston rods as a “genus” (with purportedly only two species—internally and externally threaded piston rods),¹⁵ Patent Owner does not show that the GB application provides any broad disclosure of a

¹⁵ Assuming only two species ignores the fact that the piston rod is threaded at both ends, corresponding to what would seem to be four species of threaded piston rods under Patent Owner’s own reasoning, as discussed above.

“thread” sufficient to provide written description for substitute claim 31. Further, to the extent that Patent Owner alternatively seeks through substitute claim 31 to claim all threaded piston rods as a “genus,” based on the disclosure in the GB application of only one species (an externally threaded piston rod), Patent Owner does not show sufficient written description support. To be clear, we agree with Patent Owner that it is *possible* that the disclosure of a species may provide written description support for a genus claim. *See* RMTA 11 (citing *In re Rasmussen*, 650 F.2d 1212, 1215 (C.C.P.A. 1981) (“[t]hat a claim may be broader than the specific embodiment disclosed in a specification is in itself of no moment”); *see also id.* at 10–12 (discussing *Hologic*, 884 F.3d at 1362, and *Bilstad v. Wakalopulos*, 386 F.3d 1116, 1124–25 (Fed. Cir. 2004)). Thus, although a narrow disclosure of a species (externally threaded piston rods) theoretically may provide written description support for a claim directed to a broader genus (threaded piston rods), such reasoning does not apply to substitute claim 31, because a preponderance of the evidence: (1) shows that Patent Owner was in possession of only one of the two species (externally threaded piston rods) in the supposed genus of threaded piston rods Patent Owner seeks to claim, and (2) does not show that the second species (internally threaded piston rods) was well-known in the art or interchangeable with the first species. *See* RMTA 10–11; *see also Hologic*, 884 F.3d at 1362 (explaining that disclosure of a species (a “fibre optics bundle”) provided written description support for a genus (a “light guide”) where there was no “dispute that various types of light guides were well-known in the art”).

More specifically, turning to the evidence of written description Patent Owner provides in support of substitute claim 31 in its motion, Patent Owner identifies in a table certain portions of the ’616 application and

corresponding portions of the GB application that Patent Owner asserts provide written description support for the recited “piston rod comprising a fourth thread that is engaged with the third thread.”¹⁶ RMTA 5–6 (citing Ex. 2304 ¶¶ 6, 7, 39–41; Ex. 1026, 1:25–2:13, 5:25–6:14, cls. 2, 6 (regarding Element 31[e] of Claims Appendix at 1); *see also* Ex. 2325 ¶ 23 (providing the same table). Rather than address the disclosures Patent Owner cited as purportedly providing written description support, Patent Owner instead proceeds to address “original claim 1” of the GB application, which it did not identify as providing written description support for the piston rod limitation of substitute claim 31 at issue. *See id.* Specifically, Patent Owner argues that “original claim 1” of the GB application “recites a piston rod but does not specify that it is threaded internally or externally.” RMTA 9 (citing Ex. 1026). Patent Owner’s argument implicitly mischaracterizes claim 1 of the GB application, which states as follows:

1. A pen-type injector comprising a housing;
a piston rod adapted to operate through the housing;
a dose dial sleeve located between the housing and the piston rod,
the dose dial sleeve having a helical thread of first lead;

¹⁶ Patent Owner explains that citations to the GB application (Ex. 1026) “are equivalent to the same disclosure” in the ’616 application (Ex. 2304). RMTA 6 n.5. To the extent the parties and their experts discuss what was disclosed in either the GB application or the ’616 application, unless noted otherwise, our understanding is that each application provides an equivalent disclosure to the other. *See also* Ex. 2325 ¶ 25 n.7 (Dr. Slocum stating that he cites “to the US ’616 Application throughout simply as a matter of convenience, and by doing so, [he does] not mean to imply that the corresponding disclosure in the GB Application is not also relevant,” and noting that with regard to disclosures in the ’616 application, the “same disclosure exists in the GB Application”). We follow the same approach in that our discussion of either the GB application or the ’616 application pertains to what both applications equivalently disclose.

a drive sleeve located between the dose dial sleeve and the piston rod, the drive sleeve having a helical groove of second lead; characterised in that the first lead of the helical thread and the second lead of the helical groove are the same.

Ex. 1026, 12. Patent Owner neglects to explain that not only does “original claim 1” of the GB application “not specify” whether the piston rod “is threaded internally or externally,” as Patent Owner asserts, “original claim 1” does not even specify that the piston rod is “threaded.” *See also* Ex. 2325 ¶ 28 (Dr. Slocum noting that original claim 1 “describes the piston rod without reference to threads”). Yet from this absence of disclosure, Patent Owner asserts a person of ordinary skill in the art would have “gleaned that the inventors considered their invention broader than the externally-threaded piston rod.” RMTA 9 (citing Ex. 2325 ¶¶ 25–32). Patent Owner’s explanation, on its face, fails to show written description support for substitute claim 31, even if the disclosure would have suggested some undisclosed “broader” invention. Moreover, Dr. Slocum’s opinion that the *absence* of *any* disclosure of “threads” in “original claim 1” constitutes a “signal to a person of ordinary skill that the inventors had not intended their invention to be limited to external threads” is unsupported and not credible, because it is inconsistent with the entirety of the GB application, which expressly describes only an externally threaded piston rod. *See* Ex. 2325 ¶ 28.

The remaining evidence Patent Owner presents is summarized in the following:

- a person of ordinary skill in the art would have known that “it does not matter which thread (whether on the piston rod or drive sleeve) is internal or external,” and that the location of these threads were “interchangeable” (RMTA 9 (citing Ex. 2107 ¶¶ 98–99));

- a person of ordinary skill in the art would have understood “that the threads of a piston rod could *only* be either internal or external” and “would have immediately understood that the piston rod could have either internal threads or external threads” in “each instance where the specification discloses that the piston rod has a ‘thread’” (RMTA 9–10 (citing Ex. 2325 ¶¶ 21, 28)); and
- a person of ordinary skill in the art would have had “the prior knowledge of internally threaded piston rods in other related contexts” (RMTA 10 (citing Ex. 2107 ¶¶ 95–97 (citing Exs. 2169–2171); Ex. 2325 ¶¶ 25–32)).

According to Patent Owner, the above “understandings” would have led a person of ordinary skill in the art “to conclude that the inventors here had possession of a threaded piston rod, without limitation to the specific position of the threads.” RMTA 10.

We have also considered additional testimony provided by Dr. Slocum in support of Patent Owner’s motion.¹⁷ *See* Ex. 2325 ¶¶ 23–32. Dr. Slocum states that the ’616 application describes an externally threaded piston rod 20. *Id.* ¶ 27 (citing Ex. 2304 ¶¶ 39–40, Fig. 1). We agree that the ’616 application (and the GB application) expressly disclose an externally threaded piston rod. Dr. Slocum also suggests that, because he was able to draw what he characterizes as “an exemplar of an internally threaded piston rod interacting with a drive sleeve” during his deposition, “a person of ordinary skill would read the GB Application and understand that the inventors were in possession of an invention with a drive sleeve connected to a piston rod, and that such connection could be with internal or external threads on the piston rod.” *Id.* ¶¶ 29–31. The exemplar Dr. Slocum refers to (Ex. 1051) includes a “stinger.” We find that Dr. Slocum’s drawing

¹⁷ Dr. Slocum also provided a declaration (Ex. 2332) in support of Patent Owner’s reply to RMTA, which we address below.

in a deposition in 2019 does not provide persuasive evidence of what a person of ordinary skill in the art would have understood from the '616 application or the GB application during the relevant time frame.

In this regard, we credit the testimony of Mr. Leinsing, who explains that Dr. Slocum's drawing does not reflect what a person of skill in the art would have considered a "routine or commonly-used component in pen injectors" and that "it was not conventional for pen injectors to use a drive with an internal 'stinger' that engages an internally thread piston rod." Ex. 1113 ¶ 40; *see also id.* (noting that Steinfeldt-Jensen, Burroughs, Moller, and Giambattista all teach an externally threaded piston rod and demonstrate what would have been viewed as conventional and routine). Mr. Leinsing's opinion that the '616 application "provides no discussion on how to configure, much less describe, an internally threaded piston 'rod' with an internal 'stinger' that would work" is persuasive as Mr. Leinsing explains that "a person of ordinary skill would have understood the piston rod to be already very thin," and that "additional structural concerns, such as buckling, would arise by hollowing out an already-thin component to introduce an even thinner threaded component within its space, thus requiring a larger size to address those concerns." *Id.* ¶ 43.

In opposition to the motion, Petitioner also argues that "substitute claim 31 suffers the same deficiencies as original claim 21" and that substitute claims 31–38 lack written description support in the '616 application. RMTA Opp. 2–4. Petitioner presents arguments relying

on testimony from Mr. Leinsing.¹⁸ *Id.* (citing Ex. 1096 ¶¶ 25–27).

Petitioner argues that a person of ordinary skill in the art would have understood from the '616 application “that external threads on the piston rod are required to permit connection with the drive sleeve,” because the '616 application “discloses a drive sleeve located between the dose dial sleeve and the piston rod,” and “notes that the drive sleeve connects to the piston rod for rotation along the piston rod’s second threaded portion.” *Id.* at 3 (citing Ex. 2304 ¶¶ 6, 7; Ex. 1096 ¶¶ 25–27). Petitioner also explains that the only “driving member” disclosed by the '616 application is a “drive sleeve” with inner helical groove 38, which works with external threading on piston rod 20. *Id.* at 4 (citing Ex. 1096 ¶¶ 25–27; Ex. 2304 Fig. 1). Petitioner argues that Patent Owner “fails to explain” how a person of ordinary skill in the art would have immediately discerned that the thread could also be on the inner surface of the piston rod and still interact with the drive sleeve.” *Id.* (citing *Waldemar Link GmbH & Co. v. Osteonics Corp.*, 32 F.3d 556, 558 (Fed. Cir. 1994)).

In regard to the disclosures of the '616 application Patent Owner identifies as providing written description support (i.e., Ex. 2304 ¶¶ 6, 7, 39–41), Mr. Leinsing states as follows:

As I explained previously, while paragraphs 6 and 7 of the '616 application do not explicitly specify whether the threading on the piston rod is internal or external, the paragraphs, like the

¹⁸ Mr. Leinsing provided a declaration (Ex. 1096) in support of Petitioner’s opposition to Patent Owner’s initial motion to amend, as well as a declaration (Ex. 1113) in support of Petitioner’s opposition to Patent Owner’s RMTA. Both declarations are relevant to Petitioner’s arguments against substitute claim 31, which is identical in both the motion to amend and the revised motion to amend. *Compare* Paper 34, App. A. at 1–2, *with* Paper 66, App. A at 1–2.

rest of the specification, provides crucial context as to the concentric nature of the components by disclosing a drive *sleeve* that is located between the dose dial sleeve and the piston rod (and the dose dial sleeve is located between the housing and the piston rod), where the drive *sleeve* is connected to the piston rod for rotation with respect thereto along the second threaded portion of the piston rod. *See* EX1095, ¶¶ 9–12; *see also* EX1109, 45:24–46:11.

The ordinary artisan would not read those paragraphs of the '616 application as suggesting that the threading on the piston rod could be on either the inner surface or the outer surface of the piston rod and, similarly, that the threading on the drive sleeve could be either on the inner surface or the outer surface of the drive sleeve. That is, given the position of the piston rod relative to the drive sleeve, such that the drive sleeve is located between the dose dial sleeve (which is located between the housing and the piston rod) and the piston rod, the ordinary artisan would understand that the threads of the piston rod are necessarily on the outer surface so as to allow for connection with the inner surface of the drive sleeve. Paragraphs 39-41 of the '616 application also do not disclose an internally threaded piston rod but reinforce the use of an externally threaded piston rod. Specifically, the piston rod is described as having a second thread 24 that is adapted to work within helical groove 38 that extends along the internal surface of the drive sleeve. EX2304, ¶¶ 39-41, 59; *see also* FIG. 1 (showing external thread 24 on piston rod 20); EX2325, ¶ 27 (noting that paragraphs 39 and 40 describe a specific embodiment that includes an externally threaded piston rod 20). Dr. Slocum's "stinger" approach overlooks the consistent terminology used in the '616 application—where a hollow, cylindrical, concentric component is a "sleeve" and that which is not is a "rod"—and instead sets forth a configuration where the "piston rod" is now an internally-threaded "sleeve" and the drive sleeve includes an externally-threaded "rod" attached to it.

Ex. 1113 ¶¶ 41–42.

Patent Owner's additional arguments fail to provide evidence that the inventors of the '844 patent were in possession of an internally threaded

piston rod. *See* RMTA Reply 3–8; Ex. 2332 ¶¶ 11–33. Patent Owner argues that the GB application “places no special importance” on whether the piston rod threading is internal or external, refers to the piston rod as “threaded,” and merely provides one illustrated embodiment with preferable features that shows an externally threaded piston rod, such that the “thread location is a mere implementation detail. RMTA Reply 4–5. We disagree, as Mr. Leinsing explains, the injector pen disclosed in the GB application includes components, including a drive sleeve, that essentially only function with an externally threaded piston rod, notwithstanding Dr. Slocum’s attempt to redesign the device disclosed in the GB application to add a “stinger” to the drive sleeve to then add an internally threaded piston rod. Patent Owner also argues in reply at length that Dr. Slocum’s design proves what a person of ordinary skill in the art “would have ‘immediately discerned’” because “Dr. Slocum readily envisioned such a device when prompted by Mylan’s counsel during deposition.” RMTA Reply 6–8.

For the many reasons provided above, we are not persuaded that what Dr. Slocum envisioned during a deposition in 2019 accurately reflects the understanding of a person of ordinary skill in the art at the time of the invention. Dr. Slocum’s declaration in support of the RMTA Reply highlights the very problem with his opinion—it is not based on sufficient evidence of what was known to a person of ordinary skill in the art at the time of the invention, but is instead a reflection of his personal knowledge and experience as of 2019. *See* Ex. 2332 ¶ 13–33. Dr. Slocum claims to show “how simple it is to accomplish” an internally threaded piston rod and externally threaded drive sleeve, which he calls his “‘stinger’ embodiment” by literally creating “a CAD model with engineering design calculations of the design to . . . more clearly show the arrangement of components.”

Dr. Slocum does not rely on what was disclosed in the GB application, but instead shows what he has designed in 2019, including in “parallel with the CAD modeling,” a “spreadsheet to assess force loop of the drawn embodiment” to evaluate “the efficiency of the system, reasonable stresses in components, and material/geometry considerations.” *Id.* ¶¶ 13–15, 33. Dr. Slocum even suggests that “[w]ith the CAD model of the drawn embodiment complete, it was easy for me, acting as a person of ordinary skill, to evolve the model to show the “stinger” design using an internally threaded piston rod.” *Id.* ¶ 17. Dr. Slocum does not explain how he was able to set aside his superior knowledge to act “as a person of ordinary skill” as he used the model he created to “evolve” it into his “stinger embodiment.” *See id.* Dr. Slocum proceeds to attempt to refute Dr. Leinsing’s opinion that the addition of a stinger would have presented structural concerns by discussing the properties of polyoxymethylene and how he “added the details for mechanically joining the stinger to the modified drive sleeve via a snap fit design.” *Id.* ¶¶ 19–24. Dr. Slocum also provides a table showing dozens of entries for “geometries and analysis” and an illustration comparing the “GB App. Model” (disclosed in the GB application) to his “‘Stinger’ Model.” *Id.* ¶¶ 25–33.

On the back of the extensive work Dr. Slocum performed creating a “Stinger Model,” Patent Owner proceeds to argue that it is “unsurprising” that a person of ordinary skill in the art “would have immediately discerned an internally-threaded piston rod in view of the GB Application’s disclosure,” because such a person would have been “well-versed on threaded engagements” and would have been familiar with “devices utilizing an internally-threaded piston rod driven by an externally-threaded driver.” RMTA Reply 7–8 (citing Kamen, Spinello, Moberg). We note Patent

Owner does not suggest that Kamen, Spinello, or Moberg actually teaches the use of a stinger as shown in Dr. Slocum's Stinger Model. Patent Owner concludes that Petitioner "fails to account for the real world fact that '[a] patent specification is written for a person of skill in the art, and such a person comes to the patent with the knowledge of what has come before.'" *Id.* at 8 (quoting *LizardTech*, 424 F.3d at 1345).

Petitioner argues in Sur-reply that "it is the specification itself that must demonstrate possession," and that "a description that merely renders the invention obvious does not satisfy the requirement." RMTA Sur-reply 1 (quoting *Ariad*, 598 F.3d at 1352). Petitioner further argues that Patent Owner identifies no guidance or "blaze marks" from the specification indicating possession of the undisclosed embodiment, and that Patent Owner's argument that a person of ordinary skill in the art could have made the undisclosed embodiments is insufficient. *Id.* at 1–2. Petitioner also argues that the GB application "only shows possession of an external thread," that "having a threaded drive sleeve necessarily means there is an externally-threaded piston rod," and that "having an internally threaded piston rod requires an entirely different (and definitely undescribed) driving structure, like a 'stinger.'" *Id.* at 3. According to Petitioner, whether Dr. Slocum can create "a functional stinger does not show written description support," even if it "supports the obviousness of the configuration." *Id.* at 3–4. Finally, Petitioner argues that Patent Owner "fails to direct the Board to any pen-injector art disclosing a stinger embodiment because it cannot," and that the references cited "disclose devices that (1) are not pen injectors, and (2) operate differently, with an axially-fixed screw rotating (via, e.g., a motor) to move a rotationally-fixed

nut,” not the drive mechanism of the ’844 patent. *Id.* at 4 (citing Ex. 2332 ¶ 18).

While we acknowledge Dr. Slocum apparently conceived of an attenuated way to add a “stinger” to the device disclosed in the GB application to redesign it in a way that arguably creates a functioning piston rod with internal threading, that design was not disclosed in the GB application and no evidence provided by Patent Owner sufficiently shows that a “Stinger Model” was well known or interchangeable with an externally threaded piston rod, as applied to the device disclosed in the GB application. We credit the testimony of Mr. Leinsing over the testimony of Dr. Slocum in this regard.

For these reasons, we find that Patent Owner does not show adequate support in the ’616 application or the GB application for proposed substitute claim 31. Substitute claims 32, 35, and 36 depend from substitute claim 31. Proposed substitute claims 32, 35, and 36 suffer from the same deficiency for the same reasons. Substitute claims 33, 37, and 38 depend from claim 21 and require “a piston rod comprising either an internal or an external fourth thread.” As explained above, Patent Owner does not show adequate support in the ’616 application or the GB application for “a piston rod comprising . . . an internal . . . fourth thread,” (i.e., and internally threaded piston rod). Accordingly, substitute claims 33, 37, and 38 lack the necessary written description support.

D. Conclusion

For these reasons, we find that Patent Owner’s Corrected Revised Contingent Motion to Amend does not establish adequate support in the ’616 application or the GB application for proposed substitute

claims 31–38. Thus, we deny Patent Owner’s Corrected Revised Contingent Motion to Amend.

IV. ANALYSIS OF PETITIONER’S MOTION TO EXCLUDE

Petitioner moves to exclude the following one hundred and forty-seven exhibits – Exhibits 2001–2020, 2023, 2100–2107, 2109, 2111, 2113–2126, 2128–2152, 2157–2162, 2165–2201, 2203–2212, 2214–2218, 2223–2225, 2302, 2305, 2306, 2308–2312, 2316, 2323–2325, 2327, and 2332–2334. Mot. 1. Petitioner also moves to exclude “the redirect testimony” in Exhibits 1054 and 1109. *Id.* Petitioner states that corresponding objections to the exhibits sought to be excluded were filed prior to the motion to exclude. *Id.* (citing Papers 21, 35, 36, 89). Petitioner further argues that to the extent any exhibit is not excluded, “use of the exhibit should be restricted to the use for which it was originally submitted.” *Id.* at 12 (citing Federal Rules of Evidence (“FRE”) 105). Petitioner, as the “moving party,” “has the burden of proof to establish that it is entitled to the requested relief.” 37 C.F.R. § 42.20 (2017).

A. Exhibits 2001–2011, 2013–2020, and 2023

Petitioner moves to exclude Exhibits 2001–2011, 2013–2020, and 2023 pursuant to FRE 402 and 403 because these exhibits are purportedly not relevant to any contested issue in this proceeding and risk confusing the issues. Mot. 1–4. Patent Owner responds that these exhibits “were offered to show information relevant to issues raised during this proceedings preliminary stage.” Mot. Opp. 1. Patent Owner asserts that these exhibits do not lack relevance, have no risk of confusing the issues, and should therefore remain in the record. *Id.* In reply, Petitioner argues that Patent Owner conceded Exhibits 2001–2017 pertain to pre-institution issues and failed to identify any issue remaining in the trial for which they

are relevant. Mot. Reply 1. Petitioner further asserts that, if these exhibits are not excluded, “they should be limited to the purpose for which they were submitted.” *Id.* (citing FRE 105).

We are not persuaded that exhibits offered prior to institution of *inter partes* review should be excluded after institution merely because they are no longer relevant to an issue in dispute between the parties. Indeed, the record contains other documents that may similarly be characterized as only relevant prior to institution, such as the preliminary response of the Patent Owner. These exhibits and papers are a part of the record on which institution was based and Petitioner fails to identify any persuasive reasons for their exclusion at this stage of the proceeding. Petitioner shows no risk of confusion by allowing the exhibits to remain in the record. Petitioner also fails to direct our attention to any prior Board decision that granted a motion to exclude exhibits merely because they were relevant only to the pre-institution phase of an *inter partes* review. Petitioner does not show a persuasive reason to exclude the exhibits or expressly limit their purpose pursuant to FRE 105 over the competing interest of maintaining a full record of the evidence and arguments provided by the parties, including evidence introduced only for purposes relevant to our decision on institution.

B. Exhibit 2012

Petitioner contends that Exhibit 2012 is an animation “offered to show an animated operation of an embodiment of the injection pen described in the ’844 patent” and should be excluded as hearsay pursuant to FRE 801–804 “because it is offered for the truth of its content without satisfying any of the hearsay exceptions.” Mot. 3. Patent Owner responds that an expert may rely upon hearsay if reasonable to do so in the expert’s filed, and that Dr. Slocum relied upon Exhibit 2012 “to explain the operation of the injector

pens in the challenged patents.” Mot. Opp. 1. Petitioner does not address Exhibit 2012 in its Reply. *See generally* Mot. Reply.

Patent Owner does not dispute that Exhibit 2012 constitutes hearsay and Petitioner does not dispute that Dr. Slocum was permitted to rely upon this exhibit in formulating his opinions. Accordingly, Exhibit 2012 is limited to the purpose of showing the basis for Dr. Slocum’s testimony.

C. Exhibits 2100, 2102–2106, 2113–2116, 2118–2120, 2122, 2124, 2125, 2129–2135, 2138–2141, 2145, 2146, 2151, 2157–2161, 2165–2174, 2176–2183, 2186–2200, 2203–2210, 2212, 2214, 2218, 2225, 2305, 2306, 2308–2312, 2323, 2324, and 2327

Petitioner contends Exhibits 2100, 2102–2106, 2113–2116, 2118–2120, 2122, 2124, 2125, 2129–2135, 2138–2141, 2145, 2146, 2151, 2157–2161, 2165–2174, 2176–2183, 2186–2200, 2203–2210, 2212, 2214, 2218, 2225, 2305, 2306, 2308–2312, 2323, 2324, and 2327 should be excluded pursuant to FRE 402 and 403 “because they were not discussed in the substantive papers, cannot be relevant to them, and consequently serve only to confuse and create prejudice through belated surprise.”¹⁹ Mot. 5. Petitioner further contends that Exhibits 2225, 2323, and 2324 should be excluded under FRE 403 and 802 because they “were not cited in any substantive papers and are prejudicial because it risks confusion by diverting attention away from the actual issues under review,” and they are “hearsay without exception.” Mot. 11–12. Petitioner offers no additional explanation of its arguments specific to Exhibits 2225, 2323, or 2324 to show that they are hearsay. Likewise for all of these exhibits, Petitioner identifies no support for the broad proposition that an exhibit “not discussed in

¹⁹ Exhibits 2151, 2167, 2168, 2206, 2207, and 2218 are further addressed below (Section V.H.) in light of Petitioner’s additional arguments with respect to these claims.

substantive papers” must be excluded, and offers only unsupported bald assertions that the exhibits “cannot be relevant” and “serve only to confuse and create prejudice through belated surprise.” *See* Mot. 4–5, 10; *see also* Mot. Reply 2.

Patent Owner explains that Exhibits 2100 and 2102–2106 are exhibits to the deposition of Mr. Leinsing, that Exhibit 2225 is an exhibit to Mr. McDuff’s deposition, that Exhibits 2100, 2102, 2103, 2113, 2116, 2120, 2131, 2134, 2135, 2138, 2158–2161, 2165–2171, 2173, 2174, 2176–2183, 2206, 2207, 2214, 2218, 2310, and 2311 are expressly cited in Dr. Slocum’s declaration, that Exhibits 2116, 2124, 2145, 2146, 2186–2199, 2203–2205, and 2208–2210 are expressly cited by Dr. Grabowski, and that Exhibits 2116, 2125, 2140, 2141, and 2200 are expressly cited by Dr. Goland. Mot. Opp. 2–3. Patent Owner reasons that these exhibits provide context for understanding the testimony provided by the declarants and are materials they reasonably relied upon in forming their opinions. *Id.*; *see also id.* at 3–4 (addressing the relevance of Exhibits 2305, 2306, 2308–2312, 2323, 2324, and 2327). Patent Owner also states that Dr. Slocum relied upon Exhibit 2151. *Id.* at 11–12. Petitioner argues in reply that the exhibits should nonetheless be excluded or “limited to the purpose for which they were cited.” Mot. Reply 1–2.

We have considered the parties additional arguments and conclude that Petitioner does not show any persuasive reason any of the exhibits purportedly not “discussed in the substantive papers” should be excluded.

*D. Exhibits 2101, 2121, 2123, 2126, 2128, 2136,
2137, 2142–2144, 2175, 2184, 2185, and 2201*

Petitioner contends that Exhibits 2101, 2121, 2123, 2126, 2128, 2136, 2137, 2142–2144, 2175, 2184, 2185, and 2201 “should be excluded under

FRE 402 and 403 because the properties for which they are cited (e.g., injection force and ease of use) are not required by any of the Challenged Claims so these exhibits serve only to confuse the issues and create prejudice through needless multiplication of issues.” Mot. 11. Patent Owner argues the exhibits are relevant. Mot. Opp. 12–13.

Petitioner offers no explanation or support for the notion that exhibits which pertain to properties *Petitioner alleges* are not required by any of the Challenged Claims should be excluded. Petitioner essentially concedes that the exhibits are relevant to an issue in dispute, but suggests that they be excluded because Petitioner does not agree with Patent Owner’s contentions. That simply is not a sufficient reason for exclusion.²⁰

*E. Exhibits 2107, 2302, 2316, 2325, 2332,
1054 (redirect), and 1109 (redirect)*

Petitioner seeks to exclude Exhibits 2107, 2302, 2316, 2325, 2332, 1054 (redirect), and 1109 (redirect) under FRE 702, 703, and 705. Mot. 5–9. Petitioner fails to identify at the outset of its argument what these exhibits correspond to, improperly leaving it to Patent Owner and the Board to fill in the information absent from the motion. Additionally, Petitioner fails to expressly address in any substantive manner Exhibits 2302, 2316, and 2325, and, accordingly, does not satisfy its burden to show that these exhibits should be excluded.

With respect to Exhibits 2107 and 2332, which are two of the declarations of Dr. Slocum, as well as the deposition redirect examination of Dr. Slocum in Exhibits 1054 and 1109, Petitioner argues that Dr. Slocum did

²⁰ In reply, Petitioner argues for the first time that these exhibits should be “excluded under FRE 801–804.” Mot. Reply 5. Because this argument was not raised in the Motion, it is improper.

not have personal knowledge of injection pens or the industry during the relevant time period and that Dr. Slocum relied upon Mr. Veasey, one of the named inventors of the '844 patent, for certain data and a model used for various calculations. *Id.* at 5–7. As to Exhibit 2107, Petitioner argues that “it does not provide sufficient facts or data, is not the product of reliable principles and methods, and has not applied the proper principles to the facts of this proceeding.” *Id.* at 7. Petitioner contends, as an example, that Appendices A through F “do not set forth the principles used nor do they demonstrate the calculations used in generating the spreadsheets” and, thus, “should be excluded for failing to disclose the underlying facts and data, and failing to set forth the bases of Dr. Slocum’s opinions.” *Id.* at 7–8. As to Exhibit 2332, Petitioner argues that “it is not supported by sufficient facts of record to qualify as expert testimony.” *Id.* at 8–9.

With respect to Dr. Slocum’s personal knowledge, Patent Owner correctly explains in response that “an expert need not be qualified in the pertinent art at the time of the invention,” and that neither party’s proposed definition of the ordinary level of skill in the art requires specific knowledge of, or experience with, pen injectors. Mot. Opp. 5 (citing Ex. 1011 ¶ 106; Ex. 2107 ¶ 102). Further, Patent Owner asserts that Dr. Slocum acquired knowledge of the pen injector field as of 2003 because he “(i) researched the prior art, (ii) canvassed literature on pre-critical date pen injectors, design considerations, and design standards, and (iii) conversed with those in the industry (*i.e.*, Mr. Veasey and Dr. Goland).” *Id.* at 6 (citing Ex. 2107 ¶¶ 25–61). Patent Owner also contends Dr. Slocum documented his opinions with facts and data in support of what a person of ordinary skill would have known in 2003. *Id.*

Regarding the information and model obtained from Mr. Veasey, Patent Owner asserts that Dr. Slocum performed his own investigation and research into design considerations and the state of the art, as documented in his declaration. *Id.* at 7 (citing Ex. 2107 ¶¶ 25–61). Patent Owner further asserts that much of the information provided by Mr. Veasey is undisputed, including design considerations and that the FlexPen[®] is the commercialization of an embodiment of Steinfeldt-Jensen. *Id.* at 7–8. Moreover, Patent Owner states that it “served as supplemental evidence the native spreadsheets that specify [the] principles and calculations” set forth in Appendices A through F and that “the measurements provided by Mr. Veasey are corroborated, unrebutted, and reliable.” *Id.* at 9–10 (citing Ex. 2226).

In reply, Petitioner offers no persuasive argument in support of its motion, but instead baselessly suggests that Dr. Slocum “objectively failed to act as an expert in this case.” Mot. Reply 2. Petitioner also challenges Dr. Slocum’s acceptance of Mr. Veasey’s data “without question,” contending that Dr. Slocum only did so because “he had no relevant knowledge or experience.” *Id.* at 3. Petitioner also asserts that Patent Owner hid Mr. Veasey’s involvement in Dr. Slocum’s testimony precluding Petitioner from cross-examining Mr. Veasey. *Id.* at 4.

We find that Dr. Slocum is undisputedly an expert in mechanical engineering with knowledge and experience *beyond* the level of ordinary skill in the art as the parties have proposed and we have adopted. *See Sundance, Inc. v. DeMonte Fabricating Ltd.*, 550 F.3d 1356, 1363 (Fed. Cir. 2008) (noting that “[a] witness possessing merely ordinary skill will often be qualified to present expert testimony both in patent trials and more generally”) (citations omitted). Additionally, as both parties acknowledge,

there is no requirement that an expert have personal knowledge of the technology during the specific relevant time period in order to qualify as an expert. In this regard, we find that Patent Owner and Dr. Slocum have established sufficient support, as detailed above, as to how he acquired knowledge of the specific technology at issue—the mechanical operation and design of injection pens. Further, Dr. Slocum’s reliance upon other individuals, including Mr. Veasey, to provide information upon which he based his opinions does not render him unqualified to offer an expert opinion.

Petitioner’s assertions that Patent Owner hid Mr. Veasey’s involvement are unfounded. In particular, Dr. Slocum acknowledged in Appendix B of his declaration that the “[i]nput values were provided by Mr. Robert Veasey of DCA Engineering.” Ex. 2107, App. B at 2. Thus, we find that Petitioner could have, but did not, seek to depose Mr. Veasey and therefore Petitioner’s arguments regarding Mr. Veasey’s involvement do not justify excluding Dr. Slocum’s declaration (Ex. 2107) or redirect testimony (Ex. 1054). To the extent the credibility of any of the individuals upon which Dr. Slocum relied may be in doubt, e.g., Mr. Veasey’s potential bias as a named inventor on the ’844 patent, those issues are the proper subject of cross-examination, go to the weight accorded the evidence, and do not justify excluding Dr. Slocum’s testimony on the facts presented here. And, to the extent Petitioner questions the data or model provided by Mr. Veasey, the proper recourse is to probe the bases for such during cross-examination. Therefore, Petitioner does not show that Dr. Slocum should be disqualified as an expert in this proceeding or that any of Exhibits 2107, 2302, 2316, 2325, 2332, 1054 (redirect), and 1109 (redirect) should be excluded.

F. Exhibit 2109

Petitioner contends that Exhibit 2109, the declaration of Dr. Grabowski, should be excluded under FRE 702, 703, and 705 because his opinions are based on data that Petitioner failed to provide in accordance with 37 C.F.R. § 42.65 (“Rule 42.65”). Mot. 9. Patent Owner responds that “Petitioner cites no authority that a party must file every single document that an expert considers in forming his opinions,” that it complied with Rule 42.65 by “disclosing Dr. Grabowski’s reliance on IMS Health data,” that “the underlying IMS Health data is voluminous,” and that “Petitioner independently obtained the IMS Health data and moved it into the public record” in related district court litigation. Mot. Opp. 11.

Petitioner replies that Patent Owner does not cite a rule in support of its failure to produce the data underpinning Dr. Grabowski’s testimony merely because it was voluminous, and that, even if Petitioner independently obtained the data, it was unable to “test” whether it was the same as the data relied upon by Dr. Grabowski. Mot. Reply 5. Petitioner, however, does not suggest that it sought an order from the Board requiring Patent Owner to produce the data, and shows no prejudice in light of Petitioner’s ability to obtain the data independently. Petitioner had every opportunity needed to “test” whether it was the same data by deposing Dr. Grabowski. Petitioner does not show any sufficient basis for excluding Exhibit 2109.

G. Exhibit 2111

Petitioner contends that Exhibit 2111, the Declaration of Dr. Robin S. Goland, should be excluded under FRE 702 and 703 because “her unqualified testimony contrary to her own experience demonstrates a stark failure to provide testimony that ‘is the product of reliable principles and methods.’” Mot. 9 (quoting FRE 702(c)); Mot. Reply 4–5. Petitioner’s

argument, on its face, is insufficient to support exclusion. Petitioner offers no explanation for its frivolous assertion that Dr. Goland is unqualified to offer an expert opinion in this proceeding. With regard to her experience, Dr. Goland explains in her declaration the following:

I received a Bachelor of Arts in History from Harvard University in 1976. After completing my undergraduate studies, I went on to obtain an M.D. degree from Columbia University in 1980.

After completing my internship in 1981, I undertook a residency in internal medicine at New York-Presbyterian/Columbia University from 1980-1984. I completed a fellowship in endocrinology at Columbia University College of Physicians and Surgeons in 1987. I am board-certified in Internal Medicine and Endocrinology.

Since completing my residency and fellowship, I've held a number of academic positions at Columbia University College of Physicians and Surgeons, including Assistant Professor of Clinical Medicine (1987-1989), Assistant Professor of Medicine (1990-1996), Florence Irving Associate Professor of Medicine (1997-2008), Professor of Clinical Medicine (2008-present), Professor of Clinical Medicine and Clinical Pediatrics (2010-present), and J. Merrill Eastman Professor of Clinical Diabetes (2011-present).

Since 1987, I have been the Chief of the Diabetes Clinic at New York-Presbyterian Hospital/Columbia University. In 1997, I founded the Naomi Berrie Diabetes Center at Columbia University, and I have served the center as co-director ever since. The Naomi Berrie Diabetes Center serves 14,000 patients each year, approximately 40% of which have Type 1 diabetes. In addition, the Center conducts clinical research on diabetes.

During my career, I have authored or co-authored over 80 peer reviewed articles. I am a member of the American Diabetes Association. I also served as a member of the Medical Advisory Board of the Juvenile Diabetes Foundation, New York Chapter, the Pharmacy and Therapeutics Committee of Merck Health Solutions, and the Medical Advisory Board of the NY Stem Cell Foundation.

I am an experienced clinical investigator and principal investigator in diabetes trials. In 1996-1999, I received the Irving Scholar Award for Clinical Investigation from Columbia University.

Ex. 2111 ¶¶ 2–7. We find Dr. Goland is more than sufficiently qualified to offer an expert opinion in this proceeding. Petitioner fails to show any basis for excluding Exhibit 2111.

H. Exhibits 2117, 2147–2152, 2162, 2167, 2168, 2206, 2207, 2211, and 2215–2218

Petitioner contends that Exhibits 2117, 2147–2152, 2162, 2167, 2168, 2206, 2207, 2211, and 2215–2218 are animations “offered to show animated operations of prior art and non-prior art injection pens” and should be excluded as hearsay pursuant to FRE 801–804 “because they are offered for the truth of their contents without satisfying any of the hearsay exceptions.” Mot. 10. Patent Owner responds that an expert may rely upon hearsay if reasonable to do so in the expert’s field, and that Dr. Slocum relied upon each of these exhibits “to explain the operation of the injector pens in the challenged patents, the prior art, and Petitioner’s proposed modifications to the prior art.” Mot. Opp. 11–12. Petitioner argues in reply that the exhibits are not admissible hearsay merely because they were relied upon by an expert. Mot. Reply 5.

Patent Owner does not dispute that these exhibits constitute hearsay and Petitioner does not dispute that Dr. Slocum was permitted to rely upon these exhibits in formulating his opinions. Accordingly, Exhibits 2117, 2147–2152, 2162, 2167, 2168, 2206, 2207, 2211, and 2215–2218 are limited to the purpose of showing the basis for Dr. Slocum’s testimony.

I. Exhibits 2223 and 2224

Petitioner contends that Exhibits 2223 and 2224 are “offered to show secondary considerations” and should be excluded under FRE 402, 403, 802, and 901 because they are “hearsay without exception, lack authentication, and are unreasonably prejudicial because they are cited for a new purpose.”

Mot. 11. Petitioner does not explain what the “new purpose” is, but suggests that Ex. 2223 is a “self-serving advertisement by an interested party.”

Petitioner does not identify the purported “interested part.” *Id.* Patent Owner responds with the following explanation of the exhibits at issue:

EX2223 is a press release from DCA, the designer of the SoloSTAR pen at issue in this proceeding, announcing that SoloSTAR won the 2008 Good Design Award from The Chicago Athenaeum: Museum of Architecture and Design. The exhibit is relevant to objective indicia of non-obviousness. Dr. Grabowski obtained the exhibit and cited it in his declaration. *See* EX2109 at n.92. Dr. Grabowski therefore provided the required foundation. Finally, as Dr. Grabowski is permitted to rely upon EX2223 under FRE703, there is no basis to exclude it.

Next, EX2224 was presented without objection to Petitioner’s expert Dr. McDuff during his deposition. *See* EX2318, 73:3-18, 88:7-89:20. The exhibit confirms that an academic journal (EX2116) cited in both Dr. McDuff’s and Dr. Grabowski’s declarations, was double-blind peer-reviewed and thus a reliable source of information. *See* EX1060 at n.127; EX2109 n.53. As Petitioner did not object to this exhibit at deposition, there is no basis to exclude it now.

Mot. Opp. 13–14. Petitioner does not respond to Patent Owner’s arguments in its Reply. *See generally* Mot. Reply. Petitioner fails to show any sufficient basis for excluding Exhibits 2223 and 2224, because the arguments in the motion are undeveloped, conclusory, and vague.

J. Exhibits 2333 and 2334

Petitioner contends that Exhibits 2333 and 2334 should be excluded under FRE 402 and 403 because they “are not cited in the reply and have no evidentiary value, but instead appear to be illustrated argument,” and are, therefore, “not relevant.” Mot. 10. Petitioner fails to even explain what Exhibits 2333 and 2334 are in its motion. Patent Owner explains the following:

EX2333 and EX2334 are animations of designs discussed at length in Dr. Slocum’s Declaration in Support of Sanofi’s MTA Reply (EX2332). Specifically, Dr. Slocum explains that the designs animated in EX2333 and EX2334 would have been immediately discerned by a POSITA having read the GB Application. *See* EX2332, ¶ 30 (EX2333), ¶ 36 (EX2334). EX2333 and EX2334 undermine Petitioner’s written description arguments concerning the claimed “piston rod” and “arc shaped body,” and therefore have evidentiary value.

Mot. Opp. 12. Petitioner does not specifically address Exhibits 2333 and 2334 in its Reply outside of grouping them with its argument concerning other exhibits purportedly not cited by Patent Owner. Mot. Reply 1. Petitioner does not show any persuasive reason Exhibits 2333 and 2334 should be excluded merely because they are “not cited in the reply.”

K. Summary

In summary, many of Petitioner’s arguments purportedly supporting its attack on a wide range of exhibits are poorly supported, undeveloped, not credible, and lack on their face the basic information necessary to show Petitioner is entitled to the relief requested, as explained above. Exhibits 2012, 2117, 2147–2152, 2162, 2167, 2168, 2206, 2207, 2211, and 2215–2218 are limited to the purpose of showing the basis for Dr. Slocum’s testimony.

V. CONCLUSION

Our final determination in this case is summarized below:²¹

Claim(s)	35 U.S.C. §	Reference(s)	Claim(s) Shown Unpatentable	Claims Not shown Unpatentable
21–29	103	Steenfeldt-Jensen	21–29	
30	103	Steenfeldt-Jensen, Klitgaard	30	
Overall Outcome			21–30	

Motion to Amend Outcome	Claims
Original Claims Cancelled by Amendment	
Substitute Claims Proposed in the Amendment	31–38
Substitute Claims: Motion to Amend Granted	
Substitute Claims: Motion to Amend Denied	31–38
Substitute Claims: Not Reached	

²¹ Should Patent Owner wish to pursue amendment of the Challenged Claims in a reissue or reexamination proceeding subsequent to the issuance of this decision, we draw Patent Owner’s attention to the April 2019 *Notice Regarding Options for Amendments by Patent Owner Through Reissue or Reexamination During a Pending AIA Trial Proceeding*. See 84 Fed. Reg. 16,654 (Apr. 22, 2019). If Patent Owner chooses to file a reissue application or a request for reexamination of the challenged patent, we remind Patent Owner of its continuing obligation to notify the Board of any such related matters in updated mandatory notices. See 37 C.F.R. § 42.8(a)(3), (b)(2) (2019).

VI. ORDER

In consideration of the foregoing, it is hereby:

ORDERED that claims 21–30 of the '844 patent have been proven to be *unpatentable*;

FURTHER ORDERED that Patent Owner's Corrected Revised Contingent Motion to Amend (Paper 71) is *denied*;

FURTHER ORDERED that Petitioner's Motion to Exclude (Paper 90) is *denied*; and

FURTHER ORDERED that, because this is a Final Written Decision, the parties to the proceeding seeking judicial review of the Decision must comply with the notice and service requirements of 37 C.F.R. § 90.2.

IPR2018-01682
Patent 9,526,844 B2

FOR PETITIONER:

Richard Torczon
Wesley Derryberry
Douglas Carsten
Jeffrey Guise
Nicole Stafford
Lorelei Westin
Arthur Dykhuis
Tasha Thomas
Elham Steiner
Yahn-Lin Chu

WILSON SONSINI GOODRICH & ROSATI

rtorczon@wsgr.com
wderryberry@wsgr.com
dcarsten@wsgr.com
jguise@wsgr.com
nstafford@wsgr.com
lwestin@wsgr.com
adykhuis@wsgr.com
tthomas@wsgr.com
esteiner@wsgr.com
ychu@wsgr.com

FOR PATENT OWNER:

Elizabeth Stotland Weiswasser
Anish Desai
Sudip Kundu
Kathryn Kantha
Adrian Percer
William Ansley
Matthew Sieger
Brian C. Chang
WEIL, GOTSHAL & MANGES LLP
elizabeth.weiswasser@weil.com
anish.desai@weil.com
sudip.kundu@weil.com
kathryn.kantha@weil.com
adrian.percer@weil.com

IPR2018-01682
Patent 9,526,844 B2

sutton.ansley@weil.com
matthew.sieger@weil.com
brian.chang@weil.com

W. Karl Renner
John Goetz
Joshua Griswold
Matthew Colvin
Kenneth Darby, Jr.
FISH & RICHARDSON P.C.
axf-ptab@fr.com
goetz@fr.com
griswold@fr.com
kdarby@fr.com
colvin@fr.com