



(12) **United States Patent**  
**Reardan et al.**

(10) **Patent No.:** **US 7,895,059 B2**  
(45) **Date of Patent:** **\*Feb. 22, 2011**

(54) **SENSITIVE DRUG DISTRIBUTION SYSTEM AND METHOD**

(75) Inventors: **Dayton T. Reardan**, Shorewood, MN (US); **Patti A. Engel**, Eagan, MN (US); **Bob Gagne**, St. Paul, MN (US)

(73) Assignee: **Jazz Pharmaceuticals, Inc.**, Palo Alto, CA (US)

(\* ) Notice: Subject to any disclaimer, the term of this patent is extended or adjusted under 35 U.S.C. 154(b) by 0 days.

This patent is subject to a terminal disclaimer.

6,021,392 A 2/2000 Lester et al.  
6,045,501 A 4/2000 Elsayed et al.  
6,055,507 A 4/2000 Cunningham  
6,112,182 A 8/2000 Akers et al.  
6,315,720 B1 11/2001 Williams et al.  
6,347,329 B1 2/2002 Evans  
6,561,977 B2 5/2003 Williams et al.  
6,564,121 B1 5/2003 Wallace et al.  
6,755,784 B2 6/2004 Williams et al.  
6,952,681 B2 10/2005 McQuade et al.  
7,058,584 B2 6/2006 Kosinski et al.

(Continued)

(21) Appl. No.: **12/704,097**

OTHER PUBLICATIONS

(22) Filed: **Feb. 11, 2010**

“”, NASCSA National Conference, (Nov. 2000), 8 pages.

(65) **Prior Publication Data**

(Continued)

US 2010/0138237 A1 Jun. 3, 2010

**Related U.S. Application Data**

*Primary Examiner*—Jerry O’Connor  
*Assistant Examiner*—Lena Najarian  
(74) *Attorney, Agent, or Firm*—Schwegman, Lundberg & Woessner, P.A.

(63) Continuation of application No. 10/322,348, filed on Dec. 17, 2002, now Pat. No. 7,668,730.

(51) **Int. Cl.**  
**G06Q 10/00** (2006.01)

(52) **U.S. Cl.** ..... 705/2; 705/3; 600/300

(58) **Field of Classification Search** ..... 705/2,  
705/3; 600/300

See application file for complete search history.

(57) **ABSTRACT**

A drug distribution system and method utilizes a central pharmacy and database to track all prescriptions for a sensitive drug. Information is kept in the database regarding all physicians allowed to prescribe the sensitive drug, and all patients receiving the drug. Abuses are identified by monitoring data in the database for prescription patterns by physicians and prescriptions obtained by patients. Further verification is made that the physician is eligible to prescribe the drug by consulting a separate database, and optionally whether any actions are taken against the physician. Multiple controls beyond those for normal drugs are imposed on the distribution depending on the sensitivity of the drug.

(56) **References Cited**

**U.S. PATENT DOCUMENTS**

3,556,342 A 1/1971 Guarr  
4,847,764 A 7/1989 Halvorson  
4,976,351 A 12/1990 Mangini et al.  
5,737,539 A 4/1998 Edelson et al.  
5,845,255 A 12/1998 Mayaud  
5,924,074 A 7/1999 Evans

**16 Claims, 16 Drawing Sheets**

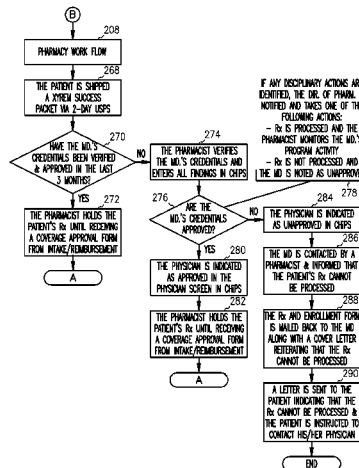

## U.S. PATENT DOCUMENTS

7,668,730 B2 2/2010 Reardon et al.  
 7,765,106 B2 7/2010 Reardan et al.  
 7,765,107 B2 7/2010 Reardan et al.  
 7,797,171 B2 9/2010 Reardan et al.  
 2001/0001144 A1 5/2001 Kapp  
 2001/0042050 A1 11/2001 Fletcher et al.  
 2001/0047281 A1 11/2001 Keresman, III et al.  
 2002/0010661 A1 1/2002 Waddington et al.  
 2002/0032581 A1 3/2002 Reitberg  
 2002/0032582 A1 3/2002 Feeney, Jr. et al.  
 2002/0042725 A1 4/2002 Mayaud  
 2002/0042762 A1 4/2002 McQuade et al.  
 2002/0052762 A1 5/2002 Kobylevsky et al.  
 2002/0161607 A1 10/2002 Subich  
 2002/0177232 A1 11/2002 Melker et al.  
 2003/0033168 A1 2/2003 Califano et al.  
 2003/0046110 A1 3/2003 Gogolak  
 2003/0050802 A1 3/2003 Jay et al.  
 2003/0093295 A1 5/2003 Lilly et al.  
 2003/0110060 A1 6/2003 Clementi  
 2003/0127508 A1 7/2003 Jones  
 2003/0144876 A1 7/2003 Kosinski et al.  
 2003/0160698 A1 8/2003 Andreasson et al.  
 2003/0197366 A1 10/2003 Kusterbeck  
 2003/0229519 A1 12/2003 Eidex et al.  
 2003/0233256 A1 12/2003 Cardenas et al.  
 2004/0008123 A1 1/2004 Carrender et al.  
 2004/0019567 A1 1/2004 Herceg et al.  
 2004/0019794 A1 1/2004 Moradi et al.  
 2004/0078237 A1 4/2004 Kaafarani et al.  
 2004/0107117 A1 6/2004 Denny  
 2004/0117126 A1 6/2004 Fetterman et al.  
 2004/0122712 A1 6/2004 Hill, Sr. et al.  
 2004/0122713 A1 6/2004 Hill, Sr. et al.  
 2004/0162740 A1 8/2004 Ericsson et al.  
 2004/0176985 A1 9/2004 Lilly et al.  
 2005/0090425 A1 4/2005 Reardan et al.  
 2005/0216309 A1 9/2005 Reardan et al.  
 2005/0222874 A1 10/2005 Reardan et al.

## OTHER PUBLICATIONS

“An Interview with Orphan Medical about Xyrem”, [http://www.talkabouteleep.com/sleepdisorders/archives/Narcolepsy\\_xyrem\\_interview.htm](http://www.talkabouteleep.com/sleepdisorders/archives/Narcolepsy_xyrem_interview.htm), (Feb. 12, 2001), 3 pgs.  
 “U.S. Appl. No. 10/322,348, Non Final Office Action mailed Jun. 17, 2005”, 26 pgs.  
 “U.S. Appl. No. 10/322,348, Advisory Action mailed Feb. 5, 2007”, 3 pgs.  
 “U.S. Appl. No. 10/322,348, Appeal Brief filed May 21, 2007”, 32 pgs.  
 “U.S. Appl. No. 10/322,348, Examiner Interview Summary mailed Oct. 21, 2009”, 3 pgs.  
 “U.S. Appl. No. 10/322,348, Final Office Action mailed Oct. 18, 2006”, 14 pgs.  
 “U.S. Appl. No. 10/322,348, Final Office Action mailed Dec. 29, 2005”, 11 pgs.  
 “U.S. Appl. No. 10/322,348, Non Final Office Action mailed Jun. 19, 2006”, 18 pgs.  
 “U.S. Appl. No. 10/322,348, Non Final Office Action mailed Jun. 29, 2005”, 12 pgs.  
 “U.S. Appl. No. 10/322,348, Notice of Allowance mailed Dec. 31, 2009”, 16 pgs.  
 “U.S. Appl. No. 10/322,348, Preliminary Amendment mailed Sep. 30, 2004”, 11 pgs.  
 “U.S. Appl. No. 10/322,348, Reply Brief filed Dec. 3, 2007”, 4 pgs.  
 “U.S. Appl. No. 10/322,348, Response filed Jan. 17, 2007 to Final Office Action mailed Oct. 18, 2006”, 17 pgs.

“U.S. Appl. No. 10/322,348, Response filed Mar. 29, 2006 to Final Office Action mailed Dec. 29, 2005”, 11 pgs.  
 “U.S. Appl. No. 10/322,348, Response filed Aug. 8, 2006 to Non Final Office Action mailed Jun. 19, 2006”, 10 pgs.  
 “U.S. Appl. No. 10/322,348, Response filed Sep. 29, 2005 to Non Final Office Action mailed Jun. 29, 2005”, 19 pgs.  
 “U.S. Appl. No. 10/731,915 Non Final Office Action mailed Oct. 5, 2004”, 21 pgs.  
 “U.S. Appl. No. 10/731,915, Non Final Office Action mailed Aug. 12, 2005”, 22 pgs.  
 “U.S. Appl. No. 10/731,915, Non Final Office Action Response mailed Feb. 2, 2005”, 17 pgs.  
 “U.S. Appl. No. 10/979,665, Non-Final Office Action mailed Nov. 17, 2009”, 19 pgs.  
 “U.S. Appl. No. 10/979,665, Notice of Allowance mailed Apr. 30, 2010”, 8.  
 “U.S. Appl. No. 10/979,665, Preliminary Amendment filed Jun. 22, 2006”, 7 pgs.  
 “U.S. Appl. No. 10/979,665, Preliminary Amendment mailed Nov. 2, 2004”, 3 pgs.  
 “U.S. Appl. No. 10/979,665, Response filed Mar. 11, 2010 to Non Final Office Action mailed Nov. 17, 2009”, 13 pgs.  
 “U.S. Appl. No. 10/979,665, Response filed Jul. 14, 2009 to Restriction Requirement mailed Jun. 25, 2009”, 8 pgs.  
 “U.S. Appl. No. 10/979,665, Restriction Requirement mailed Jun. 25, 2009”, 7 pgs.  
 “U.S. Appl. No. 11/097,651, Non-Final Office Action mailed Mar. 3, 2010”, 19 Pgs.  
 “U.S. Appl. No. 11/097,651 Notice of Allowance mailed Jul. 23, 2010”, 9 pgs.  
 “U.S. Appl. No. 11/097,651, Final Office Action mailed Nov. 12, 2009”, 14 pgs.  
 “U.S. Appl. No. 11/097,651, Non-Final Office Action mailed May 29, 2009”, 21 pgs.  
 “U.S. Appl. No. 11/097,651, Preliminary Amendment mailed Apr. 1, 2005”, 6 pgs.  
 “U.S. Appl. No. 11/097,651, Response filed Feb. 9, 2010 to Final Office Action mailed Nov. 12, 2009”, 11 pgs.  
 “U.S. Appl. No. 11/097,651, Response filed Jun. 3, 2010 to Non Final Office Action mailed Mar. 3, 2010”, 12 pgs.  
 “U.S. Appl. No. 11/097,651, Response filed Sep. 17, 2009 to Non Final Office Action mailed May 29, 2009”, 10 pgs.  
 “U.S. Appl. No. 11/097,985 Supplemental Notice of Allowability Mailed Jun. 29, 2010”, 3 pgs.  
 “U.S. Appl. No. 11/097,985, Non Final Office Action mailed Sep. 14, 2009”, 22 pgs.  
 “U.S. Appl. No. 11/097,985, Preliminary Amendment mailed Apr. 1, 2005”, 7 pgs.  
 “U.S. Appl. No. 11/097,985, Response filed Nov. 3, 2009 to Non Final Office Action mailed Sep. 14, 2009”, 15 pgs.  
 “U.S. Appl. No. 11/097,985, Notice of Allowance mailed Mar. 10, 2010”, 11 Pgs.  
 “Diversion Prevention Through Responsible Distribution”, NADDI Regional Training, (May 2001), 12 pages.  
 “Diversion Prevention Through Responsible Distribution”, NADDI Regional Training Tennessee, (Jun. 2001), 14 Pages.  
 “Diversion Prevention Through Responsible Distribution”, NADDI National Conference, (Nov. 2001), 15 pages.  
 “Peripheral and Central Nervous System Drugs Advisory Committee”, Department of Health and Human Services Food and Drug Administration Center for Drug Evaluation and Research, Holiday Inn, Bethesda, Maryland, (Jun. 6, 2001), 7 pages.  
 “Preliminary Amendment Pursuant to 37 CFR Sec. 1.115”, U.S. Appl. No. 11/104,013, filed Apr. 12, 2005, (Jun. 17, 2005), 3 pgs.  
 “System for Thalidomide Education and Prescribing Safety (S.T.E.P.S.) Starter Kit”, Celgene Corporation, (2001), 103 pgs.  
 Ukens, C., “Specialty Pharmacy”, Drug Topics, 144, (Jun. 5, 2000), 40-47.

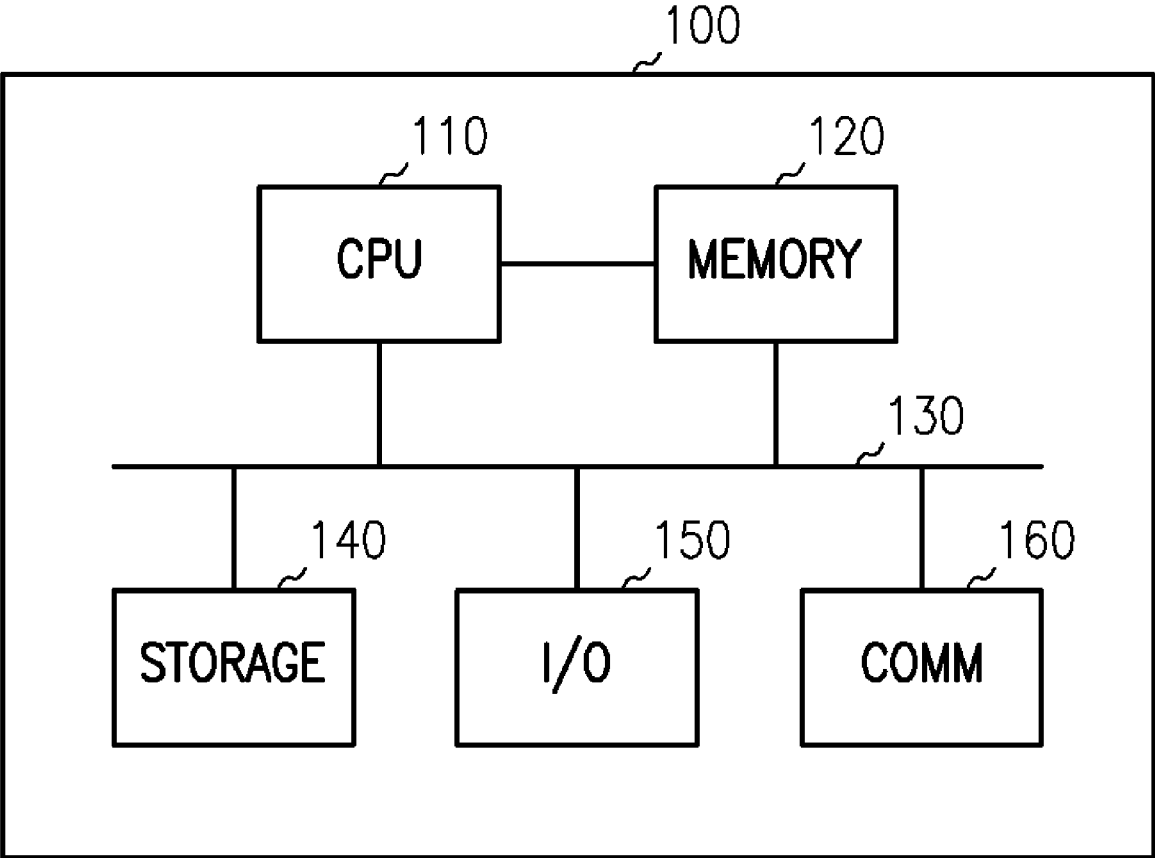

FIG. 1

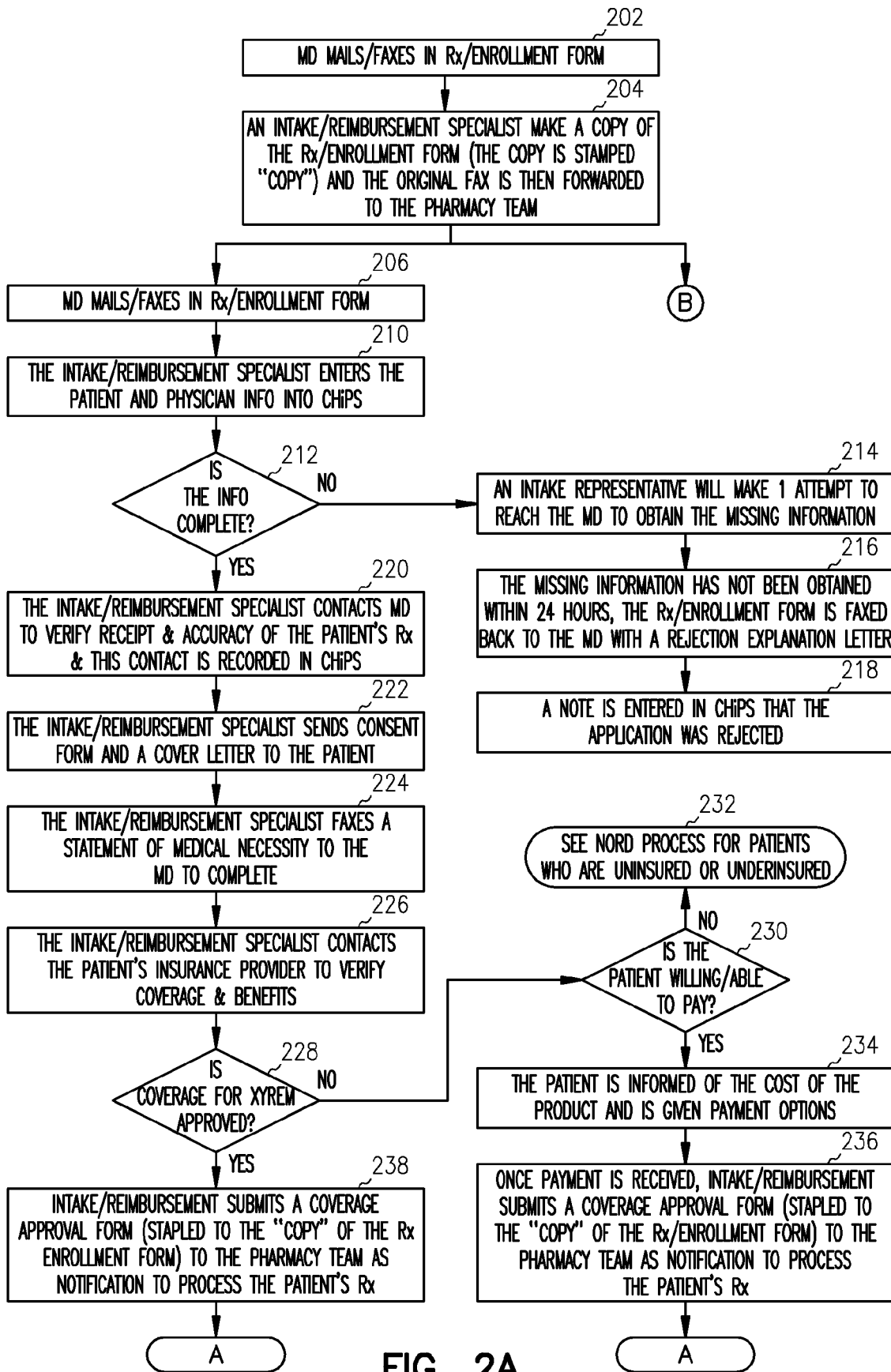

FIG. 2A

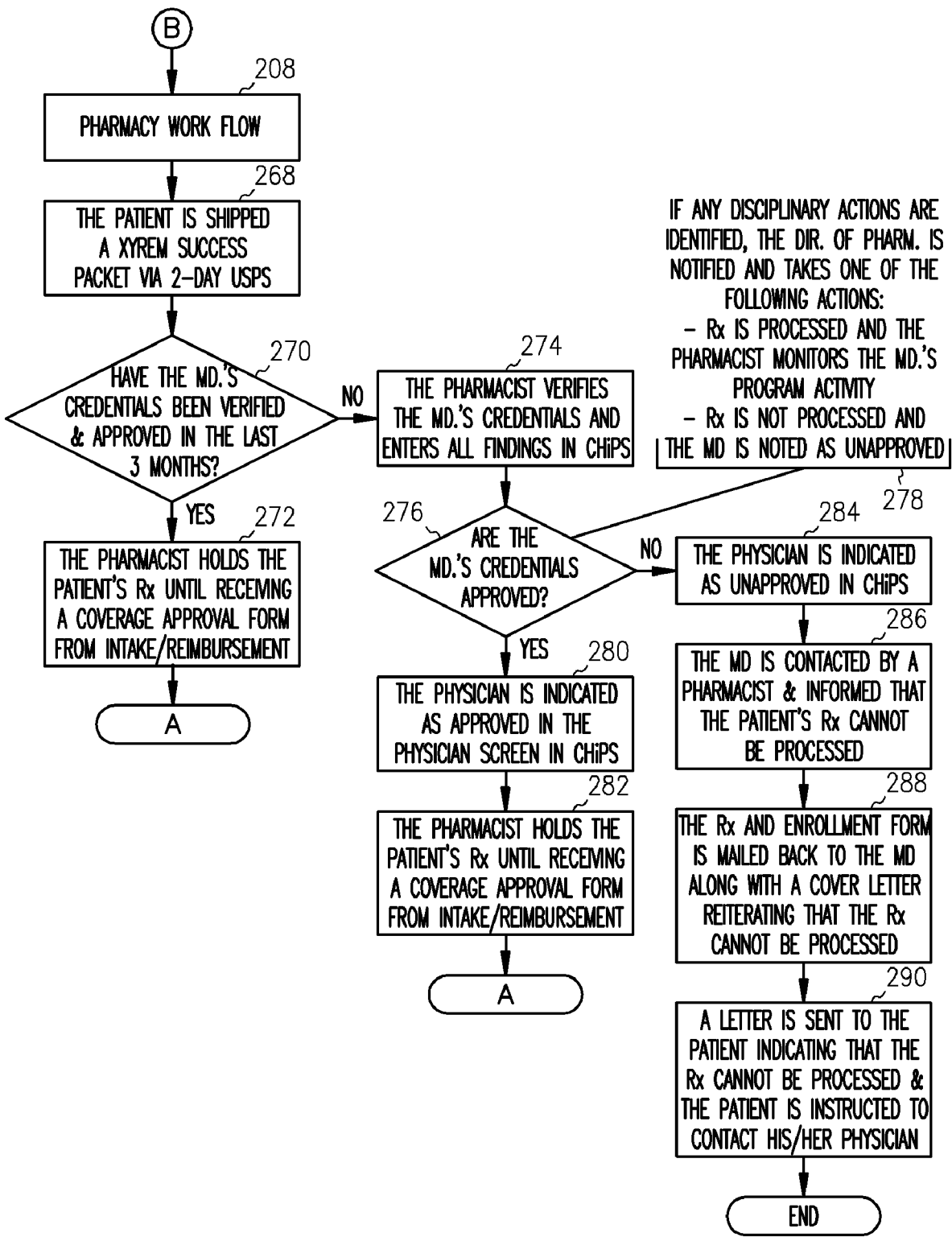

FIG. 2B

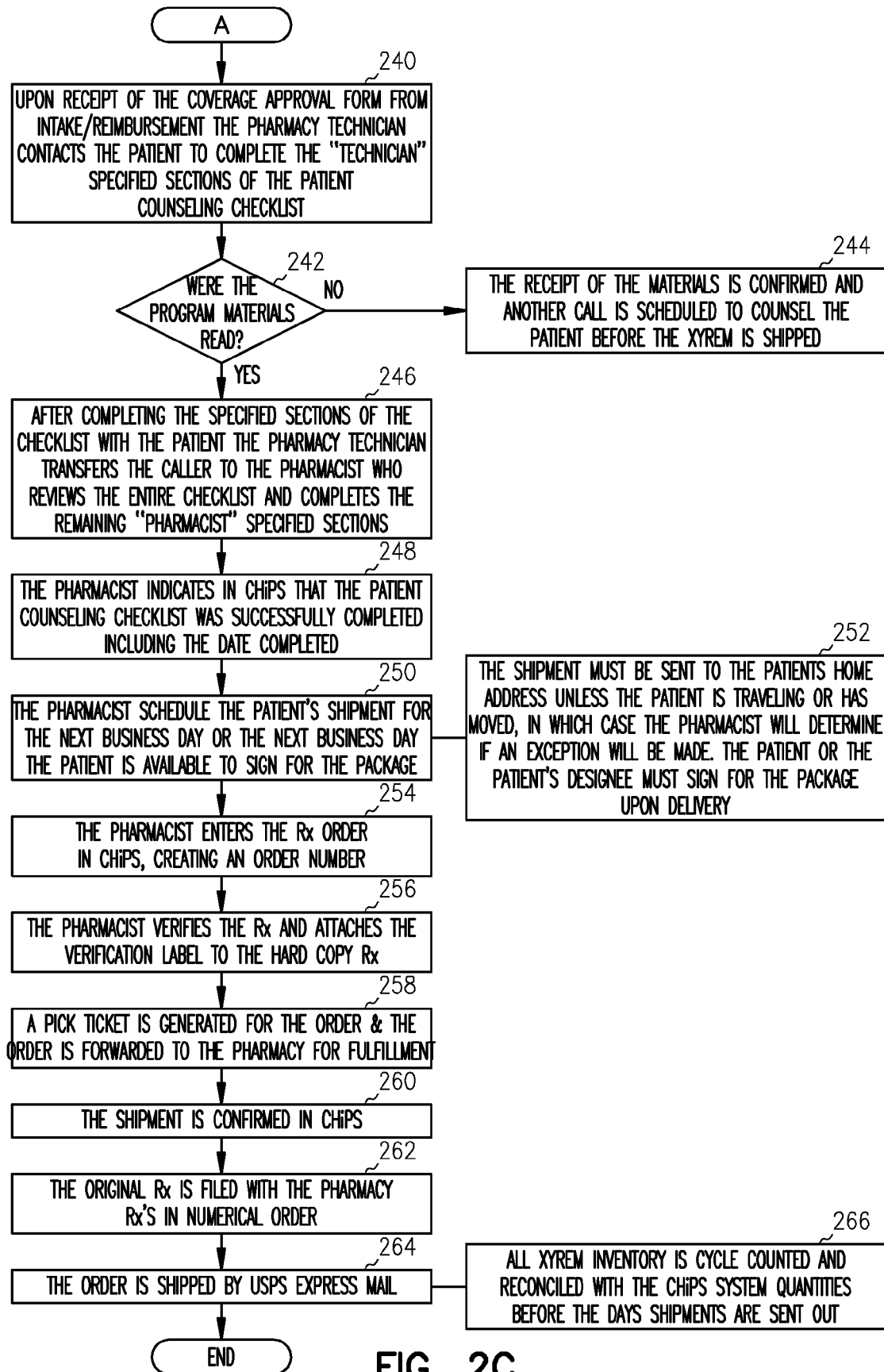

FIG. 2C

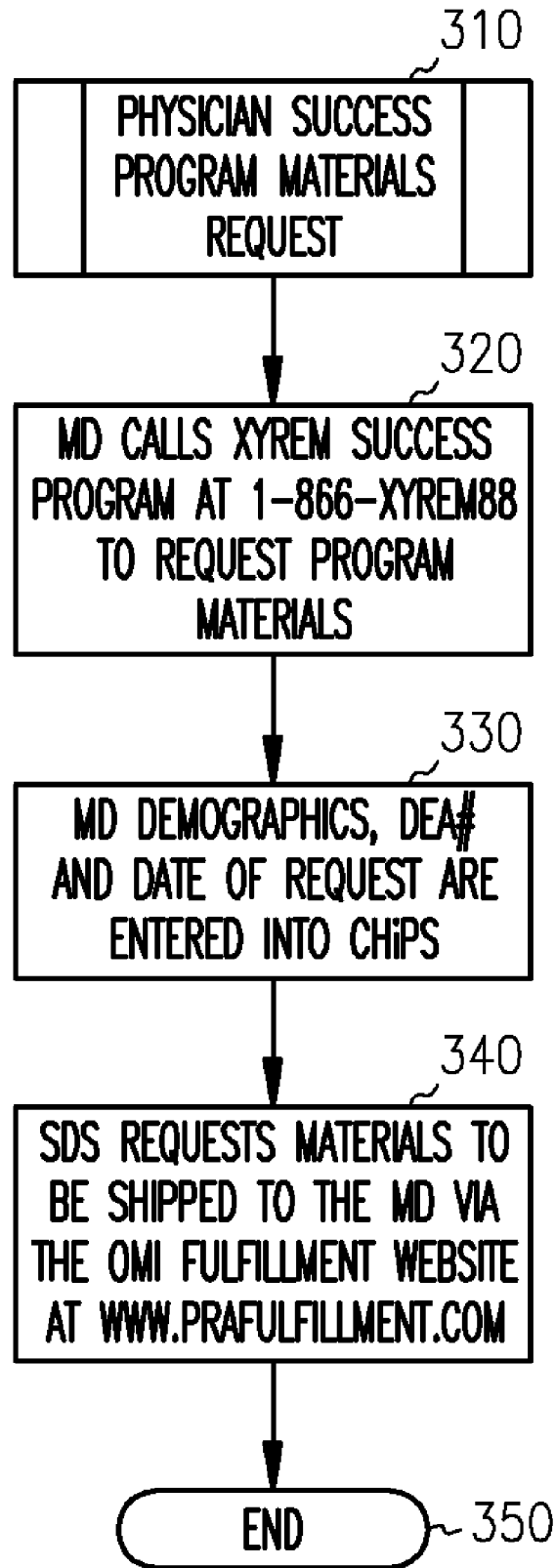

FIG. 3

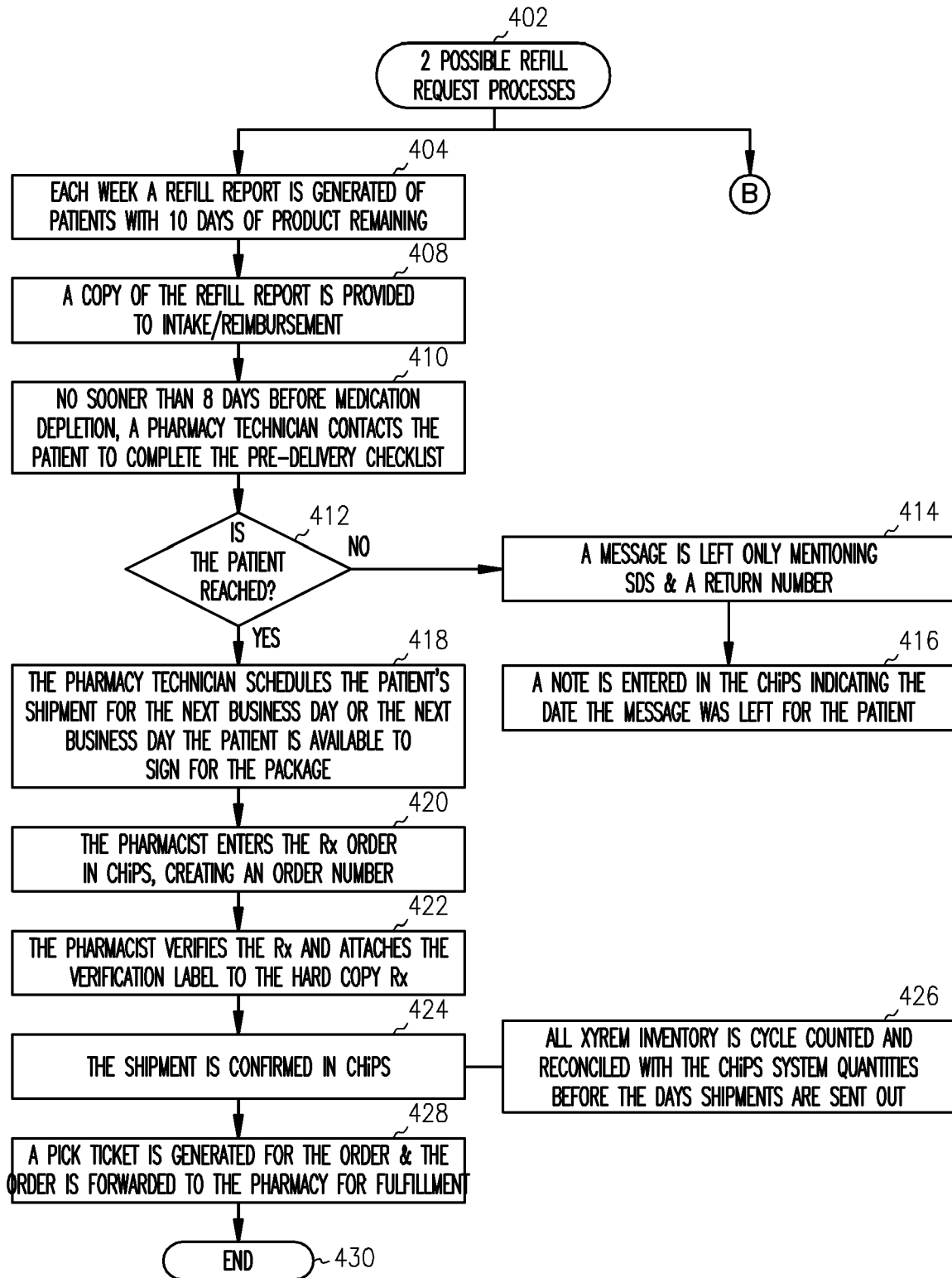

FIG. 4A



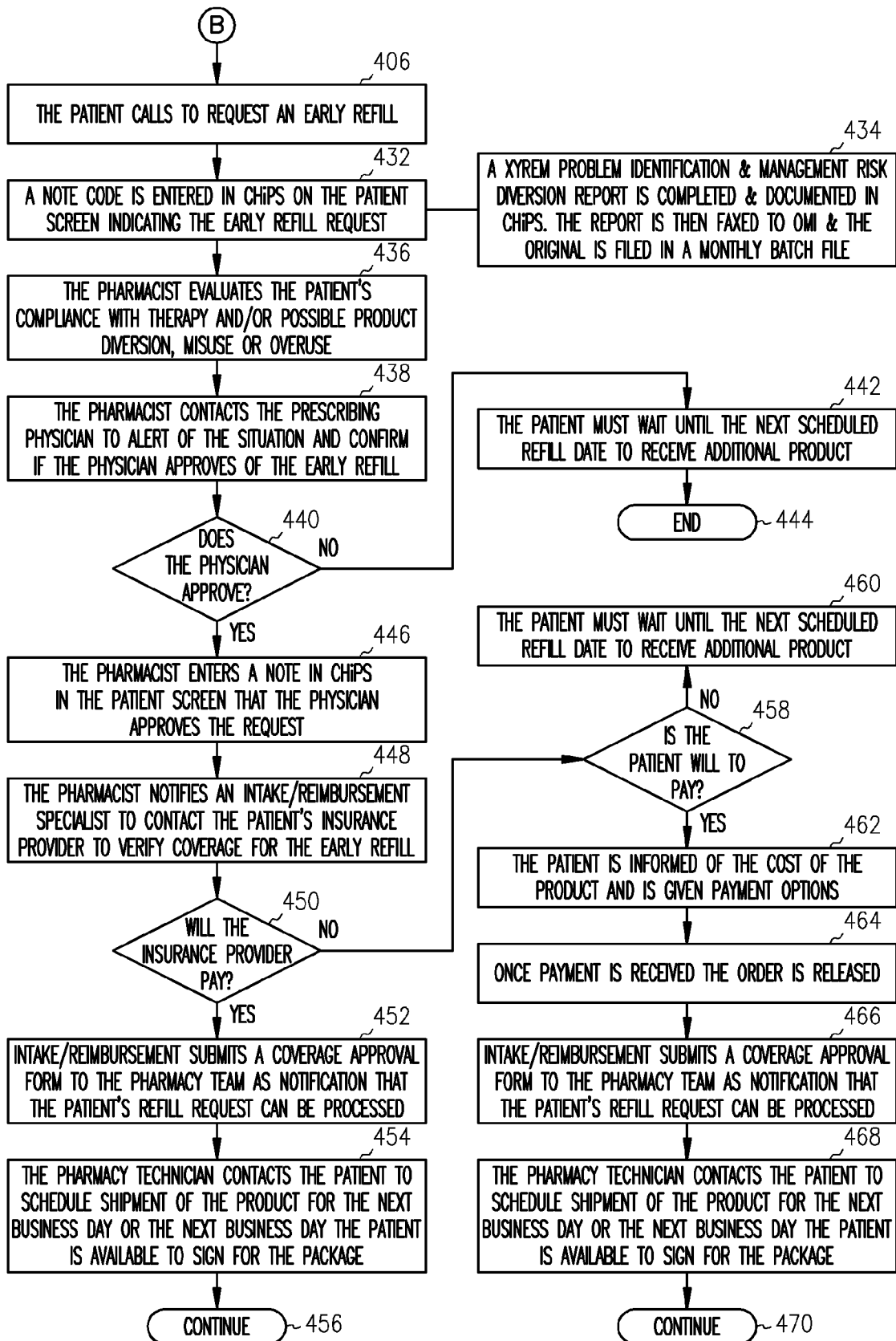

FIG. 4B

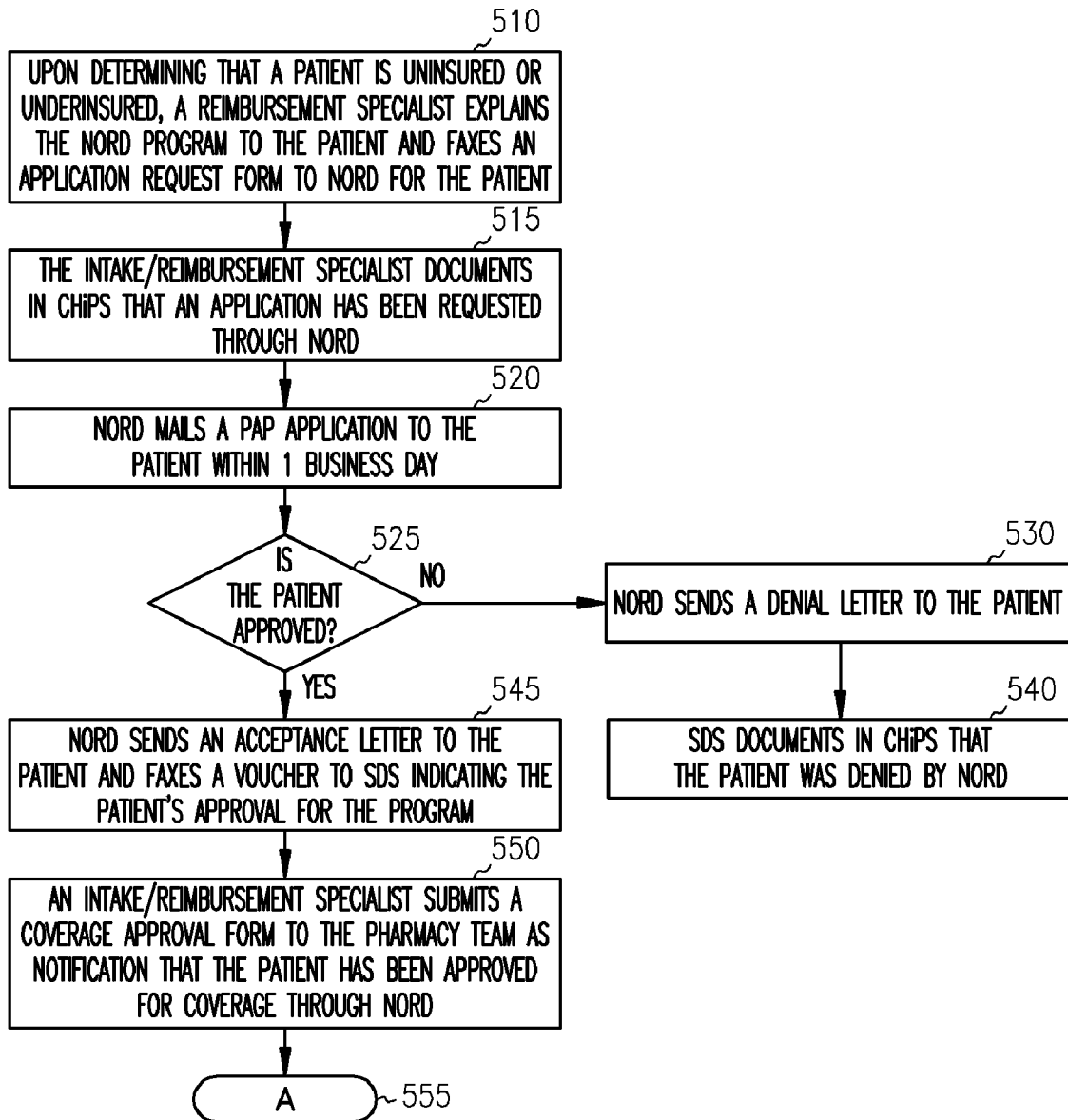

FIG. 5

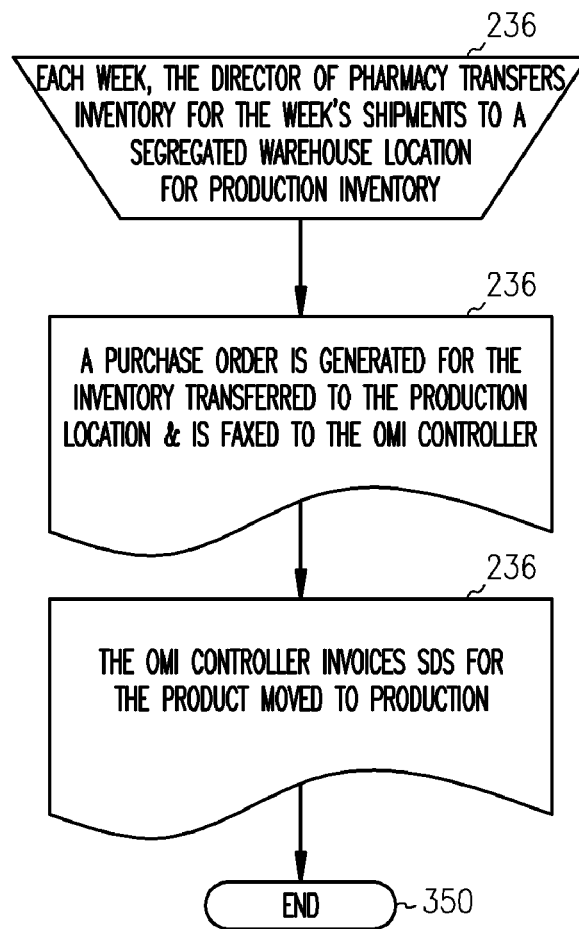

FIG. 6

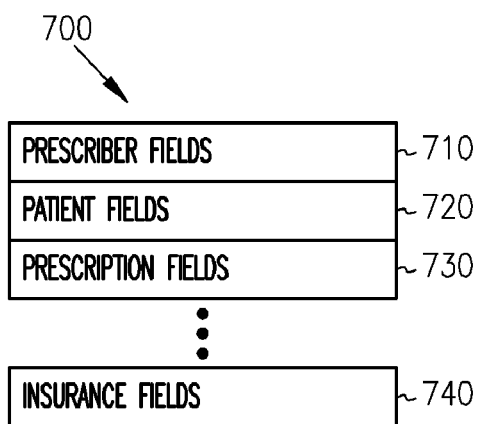

FIG. 7

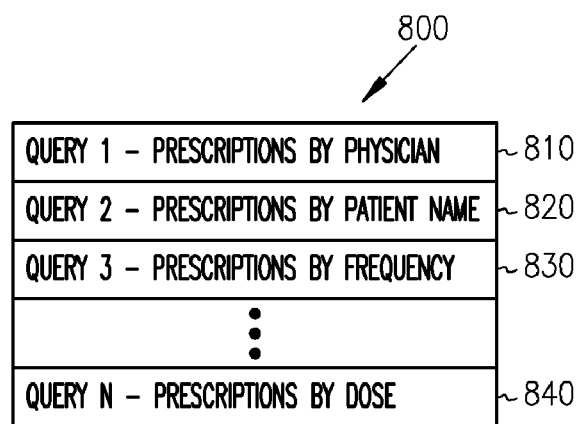

FIG. 8

900

PRESCRIPTION AND ENROLLMENT FORM

PRESCRIBER INFORMATION	
PRESCRIBER'S NAME: _____	OFFICE CONTACT: _____
STREET ADDRESS: _____	
CITY: _____	STATE: _____ ZIP: _____
PHONE: _____	FAX: _____
LICENSE NUMBER: _____	DEA NUMBER: _____
MD SPECIALTY: _____	

PRESCRIPTION FORM	
PATIENT NAME: _____	SS#: _____ DOB: _____ SEX M / F
ADDRESS: _____	
CITY: _____	STATE: _____ ZIP: _____
Rx: XYREM ORAL SOLUTION (500 mg/mL) 180 ML BOTTLE QUANTITY: _____ MONTHS SUPPLY	
SIG: TAKE _____ GMS P.O. DILUTED IN 60 mL WATER AT H.S. AND THEN AGAIN 2 1/2 TO 4 HOURS LATER	
REFILLS (CIRCLE ONE): 0 1 2 (MAXIMUM OF 3 MONTH SUPPLY)	
DATE: ____ / ____ / ____	
PRESCRIBER'S SIGNATURE _____	

PHYSICIAN DECLARATION—PLEASE CHECK EACH BOX	TO BE COMPLETED AT INITIAL PRESCRIPTION ONLY
<input type="checkbox"/> I HAVE READ THE MATERIALS IN THE XYREM PHYSICIAN SUCCESS PROGRAM	
<input type="checkbox"/> I VERIFY THAT THE PATIENT HAS BEEN EDUCATED WITH RESPECT TO XYREM PREPARATION, DOSING AND SCHEDULING.	
<input type="checkbox"/> I UNDERSTAND THAT XYREM IS APPROVED FOR THE TREATMENT OF CATAPLEXY IN PATIENTS WITH NARCOLEPSY, AND THAT SAFETY OR EFFICACY HAS NOT BEEN ESTABLISHED FOR ANY OTHER INDICATION.	
<input type="checkbox"/> I UNDERSTAND THAT THE SAFETY OF DOSES GREATER THAN 9gm/DAY HAS NOT BEEN ESTABLISHED	

PATIENT INFORMATION	
BEST TIME TO CONTACT PATIENT: <input type="checkbox"/> DAY <input type="checkbox"/> NIGHT	
DAY #: _____	EVENING #: _____
INSURANCE COMPANY NAME: _____	PHONE #: _____
INSURED'S NAME: _____	RELATIONSHIP TO PATIENT: _____
IDENTIFICATION NUMBER: _____	POLICY/GROUP NUMBER: _____
PRESCRIPTION CARD: <input type="checkbox"/> NO <input type="checkbox"/> YES IF YES, CARRIER: _____ POLICY #: _____ GROUP: _____	
PLEASE ATTACH COPIES OF PATIENT'S INSURANCE CARDS	

FAX COMPLETED FORM TO XYREM SUCCESS PROGRAM (TOLL-FREE) 1-866-470-1744  
FOR INFORMATION, CALL THE XYREM TEAM (TOLL FREE) AT 1-866-XYREM88 (1-866-997-3688)

FIG. 9

1000  
↙

PATIENT ASSISTANCE APPLICATION REQUEST FORM

DATE:

TO: PATIENT ASSISTANCE ORGANIZATION

FROM: SDS

FAX #: 203-798-2291

PLEASE SEND A XYREM PATIENT ASSISTANCE PROGRAM APPLICATION TO:

PATIENT NAME \_\_\_\_\_

ADDRESS \_\_\_\_\_

\_\_\_\_\_

TELEPHONE: ( ) \_\_\_\_\_

PATIENT DOSAGE: \_\_\_\_\_ (GRAMS) TWICE NIGHTLY FOR A TOTAL DOSAGE OF \_\_\_\_\_ (GRAMS)  
\_\_\_\_\_ BOTTLES (THREE MONTHS SUPPLY)

BACKGROUND INFORMATION:

\_\_\_\_\_

\_\_\_\_\_

\_\_\_\_\_

\_\_\_\_\_

\_\_\_\_\_

FIG. 10

SENSITIVE DRUG PATIENT ASSISTANCE PROGRAM  
VOUCHER REQUEST FOR MEDICATION

1100  
↙

PATIENT INFORMATION

<FIRST NAME><LAST NAME>  
<ADDRESS 1>  
<ADDRESS 2>  
<CITY, STATE ZIP CODE>

PHONE: <123-456-7890

DOB: 01/01/1900

SSN: 123-45-6789

DRUG ALLOTMENT: 100%

LRD: 03/01/2001

PHYSICIAN INFORMATION

<PHYSICIAN NAME>  
<ADDRESS 1>  
<ADDRESS 2>  
<CITY, STATE ZIP CODE>

PHONE: <123-456-7890

CASE CODE: \*\*\*\*\*

FIRST SHIPMENT THIS YEAR

DRUG	QUANTITY
XYREEM 180ml btl	1

VALIDATION DATE:	03/01/2001
EXPIRATION DATE:	05/31/2001
ISSUE DATE:	03/15/2001
APPROVED _____	

***PHARMACY USE***
--------------------

NORD COPY

\*\*\*\*\*

(DETACH HERE)

PATIENT INFORMATION

<FIRST NAME><LAST NAME>  
<ADDRESS 1>  
<ADDRESS 2>  
<CITY, STATE ZIP CODE>

PHONE: <123-456-7890

DOB: 01/01/1900

SSN: 123-45-6789

DRUG ALLOTMENT: 100%

LRD: 03/01/2001

PHYSICIAN INFORMATION

<PHYSICIAN NAME>  
<ADDRESS 1>  
<ADDRESS 2>  
<CITY, STATE ZIP CODE>

PHONE: <123-456-7890

CASE CODE: \*\*\*\*\*

FIRST SHIPMENT THIS YEAR

DRUG	QUANTITY
XYREM 180ml btl	1

VALIDATION DATE:	03/01/2001
EXPIRATION DATE:	05/31/2001
ISSUE DATE:	03/15/2001
APPROVED _____	

***PHARMACY USE***
--------------------

FIG. 11

1200  
↙

SENSITIVE DRUG PHYSICIAN'S CERTIFICATE  
OF MEDICAL NEED

PATIENT INFORMATION

DATE: \_\_\_\_\_

NAME: \_\_\_\_\_  
LAST FIRST M

DATE OF BIRTH: \_\_\_\_\_

DRUG BEING PRESCRIBED: XYREM

DIAGNOSIS/CONDITION FOR WHICH DRUG IS BEING PRESCRIBED: \_\_\_\_\_

ICD-9: \_\_\_\_\_

PHYSICIAN INFORMATION

PHYSICIAN'S NAME (PLEASE PRINT): \_\_\_\_\_

PHYSICIAN'S SIGNATURE: \_\_\_\_\_ DATE: \_\_\_\_\_

PLEASE FAX BACK TO SENSITIVE DRUG SUCCESS PROGRAM: (1-800-TOLL FREE NUMBER)

FIG. 12

ACTIVITY REPORTS

	REPORT FREQUENCY		
	WEEKLY	MONTHLY	QUARTERLY
<b>SALES</b>			
Rx BY ZIP (NEW AND TOTAL)	X	X	X
Rx BY PHYSICIAN BY ZIP	X	X	
\$ BY ZIP	X	X	X
<b>REGULATORY</b>			
# OF PHYSICIAN REGISTRIES		X	
# OF DENIED PHYSICIAN REGISTRIES AND REASON		X	
# OF COMPLETED PATIENT REGISTRIES		X	
# OF PROBLEM IDENTIFICATION & MANAGEMENT RISK DIVERSION REPORTS COMPLETED	X		
# OF CYCLE COUNTS PERFORMED & ACCURACY OF EACH		X	
<b>QUALITY ASSURANCE</b>			
# OF PRODUCT DEFECTS/COMPLAINTS REPORTED, TYPE AND LOT #		X	
<b>CALL CENTER</b>			
# OF CALLS RECEIVED		X	
# OF CALLS INITIATED		X	
# OF CALLS ANSWERED IN 30 SECONDS, ETC.		X	
PERCENTAGE OF CALLS ANSWERED IN 30 SECONDS		X	
# OF ABANDONED CALLS		X	
% OF ABANDONED CALLS		X	
AVERAGE CALL LENGTH		X	
<b>PHARMACY</b>			
# OF FAXED RxE/ENROLLMENT FORMS		X	
# OF MAILED RxE/ENROLLMENT FORMS		X	
# OF Rxs SHIPPED WIN 1, 2, 3, 4 ETC. DAYS (FROM THE TIME INITIAL RECEIPT TO SHIPMENT OF Rx)		X	
# OF PATIENT SUCCESS PACKETS SHIPPED		X	

FIG. 13A



ACTIVITY REPORTS

PHARMACY			X	
# OF PHYSICIAN SUCCESS PACKETS SHIPPED			X	
# OF COMPLETED SHIPMENTS			X	
# OF INCOMPLETE SHIPMENTS AND REASON			X	
# OF SHIPPING ERRORS			X	
# OF PAP SHIPMENTS			X	
# OF PAP APPLICATIONS			X	
# OF PAP APPROVALS			X	
# OF CANCELED ORDERS			X	
# OF USPS ERRORS			X	
INVENTORY			X	
# OF RETURNED PRODUCTS AND REASON			X	
# OF OUTDATED BOTTLES OF PRODUCT			X	
INVENTORY COUNTS OF CONSIGNMENT & PRODUCTION INVENTORY			X	
# OF UNITS RECEIVED			X	
LOTS RECEIVED			X	
REIMBURSEMENT			X	
# OF PENDED AND WHY			X	
# OF APPROVALS			X	
# OF DENIALS			X	
# OF REJECTIONS			X	
PAYOR TYPES			X	

FIG. 13B

ACTIVITY REPORTS

PATIENT CARE			X	
# OF ADVERSE EVENTS REPORTED AND TYPE			X	
# OF ADVERSE EVENTS SENT TO OMI			X	
# OF DOSING PROBLEMS AND TYPE			X	
# OF NONCOMPLIANCE EPISODES AND REASON			X	
# OF PATIENT COUNSELED AND REASON			X	
# OF PATIENTS DISCONTINUED AND REASON			X	
PATIENT CARE			X	
# OF PATIENTS REFERRED TO PHYSICIAN AND REASON			X	
# OF ACTIVE PATIENTS			X	
# OF NEW PATIENTS			X	
# OF RESTART PATIENTS			X	
# OF DISCONTINUED PATIENTS AND REASON			X	
DRUG INFORMATION			X	
# OF DRUG INFORMATION REQUESTS AND TYPE			X	
# OF CALLS TRIAGED TO OMI			X	

FIG. 13C

1

## SENSITIVE DRUG DISTRIBUTION SYSTEM AND METHOD

### RELATED APPLICATION

This application is a continuation of U.S. Serial application Ser. No. 10/322,348, filed on Dec. 17, 2002, which is incorporated by reference herein in its entirety.

### FIELD OF THE INVENTION

The present invention relates to distribution of drugs, and in particular to the distribution of sensitive drugs.

### BACKGROUND OF THE INVENTION

Sensitive drugs are controlled to minimize risk and ensure that they are not abused, or cause adverse reactions. Such sensitive drugs are approved for specific uses by the Food and Drug Administration, and must be prescribed by a licensed physician in order to be purchased by consumers. Some drugs, such as cocaine and other common street drugs are the object of abuse and illegal schemes to distribute for profit. Some schemes include Dr. shopping, diversion, and pharmacy thefts. A locked cabinet or safe is a requirement for distribution of some drugs.

Certain agents, such as gamma hydroxy buterate (GHB) are also abused, yet also are effective for therapeutic purposes such as treatment of daytime cataplexy in patients with narcolepsy. Some patients however, will obtain prescriptions from multiple doctors, and have them filled at different pharmacies. Still further, an unscrupulous physician may actually write multiple prescriptions for a patient, or multiple patients, who use cash to pay for the drugs. These patients will then sell the drug to dealers or others for profit.

There is a need for a distribution system and method that directly addresses these abuses. There is a further need for such a system and method that provides education and limits the potential for such abuse.

### SUMMARY OF THE INVENTION

A drug distribution system and method utilizes a central pharmacy and database to track all prescriptions for a sensitive drug. Information is kept in a central database regarding all physicians allowed to prescribe the sensitive drug, and all patients receiving the drug. Abuses are identified by monitoring data in the database for prescription patterns by physicians and prescriptions obtained by patients. Further verification is made that the physician is eligible to prescribe the drug by consulting a separate database for a valid DEA license, and optionally state medical boards to determine whether any corrective or approved disciplinary actions relating to controlled substances have been brought against the physician. Multiple controls beyond those for traditional drugs are imposed on the distribution depending on the sensitivity of the drug.

Education is provided to both physician and patient. Prior to shipping the drug for the first time, the patient is contacted to ensure that product and abuse related educational materials have been received and/or read. The patient may provide the name of a designee to the central pharmacy who is authorized to accept shipment of the drug. Receipt of the initial drug shipment is confirmed by contacting the patient. Either a phone call or other communication to the patient within a set time after delivery may be made to ensure receipt. Further, a

2

courier service's tracking system is used to confirm delivery in further embodiments. If a shipment is lost, an investigation is launched to find it.

In one embodiment, the drug may be shipped by the central pharmacy to another pharmacy for patient pick-up. The second pharmacy's ability to protect against diversion before shipping the drug must be confirmed. This ability may be checked through NTIS and State Boards of Pharmacy.

Prescription refills are permitted in the number specified in the original prescription. In addition, if a prescription refill is requested by the patient prior to the anticipated due date, such refills will be questioned. A lost, stolen, destroyed or spilled prescription/supply is documented and replaced to the extent necessary to honor the prescription, and will also cause a review or full investigation.

The exclusive central database contains all relevant data related to distribution of the drug and process of distributing it, including patient, physician and prescription information. Several queries and reports are run against the database to provide information which might reveal potential abuse of the sensitive drug, such as early refills.

### BRIEF DESCRIPTION OF THE DRAWINGS

FIG. 1 is a block diagram of a computer system for use in implementing the system and method of the present invention.

FIGS. 2A, 2B and 2C are a flowchart describing a method for sensitive drug distribution at least partially utilizing a computer system such as that shown in FIG. 1.

FIG. 3 is a flowchart of a physician success program at least partially implemented on a computer system such as that shown in FIG. 1.

FIGS. 4A and 4B are a flowchart describing a method for handling refill requests at least partially utilizing a computer system such as that shown in FIG. 1.

FIG. 5 is a flowchart of a process for requesting special reimbursement when a patient is uninsured or underinsured at least partially utilizing a computer system as that shown in FIG. 1.

FIG. 6 is a flowchart of a process for inventory control at least partially utilizing a computer system such as that shown in FIG. 1.

FIG. 7 is a block diagram of database fields.

FIG. 8 is a block diagram showing a list of queries against the database fields.

FIG. 9 is a copy of one example prescription and enrollment form.

FIG. 10 is a copy of one example of a NORD application request form for patient financial assistance.

FIG. 11 is a copy of one example voucher request for medication for use with the NORD application request form of FIG. 10.

FIG. 12 is a copy of certificate of medical need.

FIGS. 13A, 13B and 13C are descriptions of sample reports obtained by querying a central database having fields represented in FIG. 7.

### DETAILED DESCRIPTION OF THE INVENTION

In the following description, reference is made to the accompanying drawings that form a part hereof, and in which is shown by way of illustration specific embodiments in which the invention may be practiced. These embodiments are described in sufficient detail to enable those skilled in the art to practice the invention, and it is to be understood that other embodiments may be utilized and that structural, logical

and electrical changes may be made without departing from the scope of the present invention. The following description is, therefore, not to be taken in a limited sense, and the scope of the present invention is defined by the appended claims.

The functions or algorithms described herein are implemented in software or a combination of software and human implemented procedures in one embodiment. The software comprises computer executable instructions stored on computer readable media such as memory or other type of storage devices. The term "computer readable media" is also used to represent carrier waves on which the software is transmitted. Further, such functions correspond to modules, which are software, hardware, firmware of any combination thereof. Multiple functions are performed in one or more modules as desired, and the embodiments described are merely examples. The software is executed on a digital signal processor, ASIC, microprocessor, or other type of processor operating on a computer system, such as a personal computer, server or other computer system.

A sensitive drug is one which can be abused, or has addiction properties or other properties that render the drug sensitive. One example of such a drug is sodium oxybate, also known as gamma hydroxy butyrate (GHB  $C_4H_7NaO_3$ ) which is useful for treatment of cataplexy in patients with narcolepsy. GHB is marketed under the trademark of Xyrem® (sodium oxybate oral solution), which trademark can be used interchangeably with GHB herein. Sensitive drugs also include narcotics or other drugs which require controls on their distribution and use to monitor behaviors to prevent abuse and adverse side effects.

In one embodiment, Xyrem® is subject to a restricted distribution program. One aspect of the program is to educate physicians and patients about the risks and benefits of Xyrem, including support via ongoing contact with patients and a toll free helpline. Initial prescriptions are filled only after a prescriber and patient have received and read the educational materials. Further, patient and prescribing physician registries are maintained and monitored to ensure proper distribution.

In a further embodiment, bulk sodium oxybate is manufactured at a single site, as is the finished drug product. Following manufacture of the drug product, it is stored at a facility compliant with FDA Schedule III regulations, where a consignment inventory is maintained. The inventory is owned by a company, and is managed by a central pharmacy, which maintains the consignment inventory. Xyrem® is distributed and dispensed through a primary and exclusive central pharmacy, and is not stocked in retail pharmacy outlets. It is distributed by overnight carriers, or by US mail in one embodiment to potentially invoke mail fraud laws if attempts of abuse occur.

FIG. 1 is a simplified block diagram of a computer system 100, such as a personal computer for implementing at least a portion of the methods described herein. A central processing unit (CPU) 110 executes computer programs stored on a memory 120. Memory 120 in one embodiment comprises one or more levels of cache as desired to speed execution of the program and access to data on which the programs operate. The CPU is directly coupled to memory 120 in one embodiment. Both CPU 110 and memory 120 are coupled to a bus 130. A storage 140, I/O 150 and communications 160 are also coupled to the bus 130. Storage 140 is usually a long term storage device, such as a disk drive, tape drive, DVD, CD or other type of storage device. In one embodiment, storage 140 is used to house a database for use with the present invention. I/O 150 comprises keyboards, sound devices, displays and other mechanisms by which a user interacts with the com-

puter system 100. Communications 160 comprises a network, phone connection, local area network, wide area network or other mechanism for communicating with external devices. Such external devices comprise servers, other peer computers and other devices. In one embodiment, such external device comprises a database server that is used in place of the database on storage 140. Other computer system architectures capable of executing software and interacting with a database and users may also be used. Appropriate security measures such as encryption are used to ensure confidentiality. Further, data integrity and backup measures are also used to prevent data loss.

FIGS. 2A, 2B and 2C represent an initial prescription order entry process for a sensitive drug, such as Xyrem. At 202, a medical doctor (MD) sends a Rx/enrollment form via mail, fax, email or other means to an intake/reimbursement specialist at 204, who makes a copy of the RX/enrollment form that is stamped "copy". The original fax is forwarded to a pharmacy team. The enrollment form contains prescriber information, prescription information, checkboxes for the prescriber indicating they have read materials, educated the patient, understand the use in treatment, and understand certain safety information, and also contains patient information.

The prescriber information contains standard contact information as well as license number, DEA number and physician specialty. Patient and prescription information includes name, social security number, date of birth, gender, contact information, drug identification, patient's appropriate dosage, and number of refills allowed, along with a line for the prescriber's signature. Patient insurance information is also provided.

There are two workflows involved at the pharmacy team, intake reimbursement 206 and pharmacy workflow 208, which may proceed in parallel or serially. The intake workflow 206 starts with an intake reimbursement specialist entering the patient and physician information into an application/database referred to as CHIPS, which is used to maintain a record of a client home infusion program (CHIP) for Xyrem®. A check is made to ensure the information is complete at 212. If not, at 214, an intake representative attempts to reach the MD or prescriber to obtain the missing information. If the missing information has not been obtained within a predetermined period of time, such as 24 hours at 216, the Rx/Enrollment form is sent back to the MD with a rejection explanation. A note is entered in CHIPS that the application was rejected.

If the information is complete at 212, the MD is contacted at 220 to verify receipt and accuracy of the patient's Rx. This contact is recorded in CHIPS. The intake and reimbursement specialist then sends a consent form and a cover letter to the patient at 224. The insurance provider is contacted at 226 to verify coverage and benefits. At 228, a determination is made regarding coverage for the drug. If it is not available, it is determined at 230 whether the patient is willing and able to pay. If not, a process is performed for handling patients who are uninsured or underinsured. In one embodiment, the process is referred to as a NORD process.

If the patient is willing and able to pay at 230, the patient is informed of the cost of the product and is given payment options at 234. At 236, once payment is received, the intake reimbursement specialist submits a coverage approval form with the enrollment form to the pharmacy team as notification to process the patient's prescription. If coverage is approved at 228, the intake reimbursement specialist also submits the coverage approval form with the enrollment form to the pharmacy team as notification to process the patient's prescription. Processing of the prescription is described below.

5

Upon receipt and initial processing of the prescription enrollment form and sending an original to the pharmacy work flow block 208, the patient is shipped a Xyrem® success packet via mail. In one embodiment, the Xyrem® success packet contains educational material for a patient that advises of the proper use, care and handling of the drug and consequences of diversion at 268. The medical doctor's credentials are checked to determine if the physician has a current DEA license to prescribe controlled substances and if he or she has had any actions related to misuse/misprescribing of controlled drugs against him or her, within a predetermined time, such as three months at 270. If they have, a pharmacist holds the prescription until receiving a coverage approval form from the intake reimbursement specialist at 272.

If the credentials have not been recently checked, the pharmacist verifies the credentials and enters all findings in the database at 274. If the credentials are approved at 276, the physician is indicated as approved in a physician screen populated by information from the database at 280. The prescription is then held pending coverage approval at 282.

If any disciplinary actions are identified, as referenced at block 278, management of the pharmacy is notified and either approves processing of the prescription with continued monitoring of the physician, or processing of the prescription is not performed, and the physician is noted in the database as unapproved at 284. The enrollment form is then mailed back to the physician with a cover letter reiterating that the prescription cannot be processed at 288. The patient is also sent a letter at 290 indicating that the prescription cannot be processed and the patient is instructed to contact their physician.

Actual filling of the approved prescription begins with receipt of the coverage approval form as indicated at 240. The patient is contacted by the pharmacy, such as by a technician to complete a technician section of a patient counseling checklist. If a pharmacist verifies that the program materials were not read at 242, the receipt of the material is confirmed at 244 and another call is scheduled to counsel the patient before the drug is shipped.

If the program materials, were read at 242, the checklist is completed at 246 and the technician transfers the patient to the pharmacist who reviews the entire checklist and completes remaining pharmacist specified sections. At 248, the pharmacist indicates in the database that the patient counseling and checklist was successfully completed, indicating the date completed.

At 250, the pharmacist schedules the patient's shipment for the next business day or the next business day that the patient or designee is able to sign for the package. Further, as indicated at 252, the shipment must be sent to the patient's home address unless the patient is traveling or has moved. In that event, the pharmacist may determine that an exception may be made. The patient or the patient's designee who is at least 18 years old, must sign for the package upon delivery.

At 254, the pharmacist enters the prescription order in the database, creating an order number. The pharmacist then verifies at 256 the prescription and attaches a verification label to the hard copy prescription. At 258, a pick ticket is generated for the order and the order is forwarded to the pharmacy for fulfillment. The shipment is confirmed in the database at 260, and the order is shipped by USPS Express Mail. Use of the US mail invokes certain criminal penalties for unauthorized diversion. Optionally, other mail services may be used. Potential changes in the law may also bring criminal penalties into play. Following shipment, the patient is called by the central pharmacy to confirm that the prescription was received.

6

As noted at 266, for the sensitive drug, Xyrem, all inventory is cycle counted and reconciled with the database system quantities before shipments for the day are sent. This provides a very precise control of the inventory.

A physician success program materials request process begins at 310 in FIG. 3. At 320, the MD calls to the central pharmacy to request program materials. A special phone number is provided. MD demographics, DEA number, and data or request are entered into the database at 330. At 340, a request is made to ship the materials to the MD via a fulfillment website, or other mechanism. The request process ends at 350.

A refill request process begins at 302 in FIGS. 4A and 4B. There are two different paths for refills. A first path beginning at 404 involves generating a report from the central database of patients with a predetermined number of days or product remaining. A second path beginning at 406 is followed when a patient calls to request an early refill.

In the first path, a copy of the report is provided to an intake reimbursement specialist at 408. No sooner than 8 days before the medication depletion, a pharmacy technician contacts the patient at 410 to complete the pre-delivery checklist. At 412, if the patient is not reached, a message is left mentioning the depletion, and a return number at 414. A note is also entered into the database indicating the date the message was left at 416.

If the patient is reached at 412, the next shipment is scheduled at 418, the prescription is entered into the database creating an order at 420, the pharmacist verifies the prescription and attaches a verification label at 422 and the shipment is confirmed in the database at 424. Note at 426 that the inventory is cycle counted and reconciled with the database quantities before the shipments for a day or other time period are sent. A pick ticket is generated for the order and the order is forwarded for fulfillment at 428, with the first path ending at 430.

The second path, beginning at 406 results in a note code being entered into the database on a patient screen indicating an early refill request at 432. The pharmacist evaluates the patient's compliance with therapy or possible product diversion, misuse or over-use at 436. In one embodiment, cash payers are also identified. The pharmacist then contacts the prescribing physician to alert them of the situation and confirm if the physician approves of the early refill at 438. If the physician does not approve as indicated at 440, the patient must wait until the next scheduled refill date to receive additional product as indicated at 442, and the process ends at 444.

If the physician approves at 440, the pharmacist enters a note in the database on a patient screen that the physician approves the request at 446. The pharmacist notifies an intake reimbursement specialist to contact the patient's insurance provider to verify coverage for the early refill at 448. If the insurance provider will pay as determined at 450, the specialist submits the coverage approval form as notification that the refill may be processed at 452. At 454, the pharmacy technician contacts the patient to schedule shipment of the product for the next business day, and the process of filling the order is continued at 456 by following the process beginning at 240.

If the insurance provider will not pay at 450, it is determined whether the patient is willing and/or able to pay at 458. If not, the patient must wait until the next scheduled refill date to receive additional product at 460. If it was determined at 458 that the patient was willing and able to pay, the patient is informed of the cost of the product and is given payment options at 462. Once payment is received as indicated at 464, the specialist submits a coverage approval form to the pharmacy team as notification that the refill request can be pro-

cessed at **466**. At **468**, the pharmacy technician contacts the patient to schedule shipment. The process of filling the order is continued at **470** by following the process beginning at **240**.

A process, referred to as a NORD process in one embodiment is used to determine whether donated, third party funds are available for paying for prescriptions where neither insurance will, nor the patient can pay. The process begins at **510** upon determining that a patient is uninsured or underinsured. A reimbursement specialist explains the NORD program to the patient and faxes an application request form to NORD for the patient. At **515**, the intake reimbursement specialist documents in the database that an application has been received through NORD. At **520**, NORD mails an application to the patient within one business day.

A determination is made at **525** by NORD whether the patient is approved. If not, at **530**, NORD sends a denial letter to the patient, and it is documented in the database at **540** that the patient was denied by NORD. If the patient is approved, NORD sends an acceptance letter to the patient and faxes a voucher to the central pharmacy (SDS in one embodiment) to indicate the approval at **545**. At **550**, an intake reimbursement specialist submits a coverage approval form to the pharmacy team as notification that the patient has been approved for coverage. The process of filling the order is continued at **555** by following the process beginning at **240**.

An inventory control process is illustrated in FIG. 6 beginning at **610**. Each week, a responsible person at the central pharmacy, such as the director of the pharmacy transfers inventory for the week's shipments to a segregated warehouse location for production inventory. At **620**, a purchase order is generated for the inventory transferred to the production location and is sent, such as by fax, to a controller, such as the controller of the company that obtained approval for distribution and use of the sensitive drug. At **630**, the controller invoices the central pharmacy for the product moved to production. The process ends at **640**.

The central database described above is a relational database running on the system of FIG. 1, or a server based system having a similar architecture coupled to workstations via a network, as represented by communications **160**. The database is likely stored in storage **140**, and contains multiple fields of information as indicated at **700** in FIG. 7. The organization and groupings of the fields are shown in one format for convenience. It is recognized that many different organizations or schemas may be utilized. In one embodiment, the groups of fields comprise prescriber fields **710**, patient fields **720**, prescription fields **730** and insurance fields **740**. For purposes of illustration, all the entries described with respect to the above processes are included in the fields. In further embodiments, no such groupings are made, and the data is organized in a different manner.

Several queries are illustrated at **800** in FIG. 8. There may be many other queries as required by individual state reporting requirements. A first query at **810** is used to identify prescriptions written by physician. The queries may be written in structured query language, natural query languages or in any other manner compatible with the database. A second query **820** is used to pull information from the database related to prescriptions by patient name. A third query **830** is used to determine prescriptions by frequency, and a  $n^{th}$  query finds prescriptions by dose at **840**. Using query languages combined with the depth of data in the central database allows many other methods of investigating for potential abuse of the drugs. The central database ensures that all prescriptions, prescribers and patients are tracked and subject to such investigations. In further embodiments, the central database may

be distributed among multiple computers provided a query operates over all data relating to such prescriptions, prescribers and patients for the drug.

An example of one prescription and enrollment form is shown at **900** in FIG. 9. As previously indicated, several fields are included for prescriber information, prescription information and patient information.

FIG. 10 is a copy of one example NORD application request form **1000** used to request that an application be sent to a patient for financial assistance.

FIG. 11 is a copy of one example application **1100** for financial assistance as requested by form **1000**. The form requires both patient and physician information. Social security number information is also requested. The form provides information for approving the financial assistance and for tracking assistance provided.

FIG. 12 is a copy of one example voucher request for medication for use with the NORD application request form of FIG. 10. In addition to patient and physician information, prescription information and diagnosis information is also provided.

FIGS. 13A, 13B and 13C are descriptions of sample reports obtained by querying a central database having fields represented in FIG. 7. The activities grouped by sales, regulatory, quality assurance, call center, pharmacy, inventory, reimbursement, patient care and drug information. Each report has an associated frequency or frequencies. The reports are obtained by running queries against the database, with the queries written in one of many query languages.

While the invention has been described with respect to a Schedule III drug, it is useful for other sensitive drugs that are DEA or Federally scheduled drugs in Schedule II-V, as well as still other sensitive drugs where multiple controls are desired for distribution and use.

The invention claimed is:

1. A computerized method of distributing a prescription drug under exclusive control of an exclusive central pharmacy, the method comprising:

receiving in a computer processor all prescription requests, for any and all patients being prescribed the prescription drug, only at the exclusive central pharmacy from any and all medical doctors allowed to prescribe the prescription drug, the prescription requests containing information identifying patients, the prescription drug, and various credentials of the any and all medical doctors;

requiring entering of the information into an exclusive computer database associated with the exclusive central pharmacy for analysis of potential abuse situations, such that all prescriptions for the prescription drug are processed only by the exclusive central pharmacy using only the exclusive computer database;

checking with the computer processor the credentials of the any and all doctors to determine the eligibility of the doctors to prescribe the prescription drug;

confirming with a patient that educational material has been received and/or read prior to shipping the prescription drug;

checking the exclusive computer database for potential abuse of the prescription drug;

mailing or sending by courier the prescription drug to the patient only if no potential abuse is found by the patient to whom the prescription drug is prescribed and the doctor prescribing the prescription drug;

confirming receipt by the patient of the prescription drug; and

generating with the computer processor periodic reports via the exclusive computer database to evaluate potential diversion patterns.

2. The method of claim 1, wherein the exclusive central pharmacy controls the exclusive computer database.

3. The method of claim 1, comprising selectively blocking shipment of the prescription drug to a patient.

4. The method of claim 1, wherein an abuse pattern is associated with a patient, and shipment is blocked upon such association.

5. The method of claim 1, wherein the prescription drug comprises gamma hydroxy butyrate (GHB).

6. A computerized method of distributing a prescription drug under control of an exclusive central pharmacy, the method comprising:

receiving in a computer processor prescription requests, for any and all patients being prescribed the prescription drug, only at the central pharmacy from any and all authorized prescribers allowed to prescribed the prescription drug, the prescription requests containing information identifying patients, the prescription drug, and various credentials of the any and all authorized prescribers;

entering the information into an exclusive computer database under exclusive control of the central pharmacy for analysis of potential abuse situations, wherein the use of the exclusive computer database is required for distribution of the prescription drug, such that all prescriptions for the prescription drug are processed only by the exclusive central pharmacy using only the exclusive computer database;

checking with the computer processor the credentials of the any and all authorized prescribers to determine the eligibility of the prescribers to prescribe the prescription drug;

confirming with a patient that educational material has been received and/or read prior to providing the prescription drug to the patient;

requiring checking of the exclusive computer database for potential abuse associated with the patient and the authorized prescriber;

providing the prescription drug to the patient only provided information in the exclusive computer database is not indicative of potential abuse by the patient to whom the prescription drug is prescribed and the authorized prescriber of the prescription drug;

confirming receipt by the patient of the prescription drug; and

generating with the computer processor periodic reports via the exclusive computer database to evaluate potential diversion patterns.

7. The computerized method of claim 6, wherein providing the prescription drug to the patient comprises the central pharmacy authorizing the prescription drug to be dispensed to the patient by another pharmacy.

8. The computerized method of claim 7, wherein the another pharmacy places controls on the distribution of the prescription drug, the controls selected from the group consisting of confirming with the patient that the educational material has been received and/or read by the patient, confirming receipt of the prescription drug by the patient, contacting the patient's insurance company, questioning early refill requests by the patient, flagging repeat instances of lost, stolen, destroyed or spilled prescriptions, flagging that the patient paid cash for the prescription drug, flagging early requests to refill the prescription drug, and limiting the prescription to a supply of limited duration.

9. A computerized method of distributing gamma hydroxy butyrate (GHB) under control of an exclusive central pharmacy, the method comprising:

receiving in a computer processor prescription requests for GHB, for any and all patients being prescribed GHB, only at the central pharmacy from any and all authorized prescribers allowed to prescribe GHB, the prescription requests for GHB containing information identifying patients and various credentials of the any and all authorized prescribers;

entering the information into an exclusive computer database under exclusive control of the central pharmacy for analysis of potential abuse situations, wherein the use of the exclusive computer database is required for distribution of GHB, such that all prescriptions for GHB are processed only by the exclusive central pharmacy using only the exclusive computer database;

checking with the computer processor the credentials of the any and all authorized prescribers to determine the eligibility of the prescribers to prescribe GHB;

confirming with the patient that GHB educational material has been received and/or read prior to providing GHB to the patient a first time;

requiring checking of the exclusive computer database for potential GHB abuse associated with the patient;

providing GHB to the patient only provided information in the exclusive computer database is not indicative of potential abuse by the patient to whom GHB is prescribed and the authorized prescriber of the GHB;

confirming receipt by the patient of the GHB; and

generating with the computer processor periodic reports via the exclusive computer database to evaluate potential GHB diversion patterns.

10. The computerized method of claim 9, wherein providing GHB to the patient comprises the central pharmacy authorizing the prescription drug to be dispensed to the patient by another pharmacy.

11. The computerized method of claim 10, wherein the another pharmacy places controls on the distribution of GHB, the controls selected from the group consisting of confirming with the patient that the educational material has been received and/or read by the patient, confirming receipt of GHB by the patient, contacting the patient's insurance company, questioning early refill requests by the patient, flagging repeat instances of lost, stolen, destroyed or spilled prescriptions, flagging that the patient paid cash for GHB, flagging early requests to refill the GHB, and limiting the prescription to a supply of limited duration.

12. A computerized method of distributing gamma hydroxy butyrate (GHB) under control of an exclusive central pharmacy, the method comprising:

receiving in a computer processor prescription requests for GHB, for any and all patients being prescribed GHB, only at the central pharmacy from any and all authorized prescribers allowed to prescribe GHB, the prescription requests containing information identifying patients and various credentials of the any and all authorized prescribers;

entering the information into an exclusive computer database under exclusive control of the central pharmacy for analysis of potential abuse situations, wherein the use of the exclusive computer database is required for distribution of GHB, such that all prescriptions for GHB are processed only by the exclusive central pharmacy using only the exclusive computer database;

11

checking with the computer processor the credentials of the any and all authorized prescribers to determine the eligibility of the prescribers to prescribe GHB;  
 confirming with the patient that GHB educational material has been received and/or read prior to providing GHB to the patient a first time;  
 requiring checking of the exclusive computer database for potential GHB abuse associated with the patient;  
 mailing or sending by courier GHB to the patient only provided information in the exclusive computer database is not indicative of potential abuse by the patient to whom GHB is prescribed and the authorized prescriber of the GHB;  
 confirming receipt by the patient of the GHB; and  
 generating with the computer processor periodic reports via the exclusive computer database to evaluate potential GHB diversion patterns.

**13.** A computerized method of distributing gamma hydroxy butyrate (GHB) under control of an exclusive central pharmacy, the method comprising:  
 manufacturing GHB;  
 providing manufactured GHB only to the exclusive central pharmacy;  
 receiving in a computer processor all prescription requests for GHB, for any and all patients being prescribed GHB, only at the central pharmacy from any and all authorized prescribers allowed to prescribe GHB, the prescription requests containing information identifying patients and various credentials of the any and all authorized prescribers;  
 entering the information into an exclusive computer database under exclusive control of the central pharmacy for analysis of potential abuse situations, wherein the use of the exclusive computer database is required for distribution of GHB, such that all prescriptions for GHB are processed only by the exclusive central pharmacy using only the exclusive computer database;  
 checking with the computer processor the credentials of the any and all authorized prescribers to determine the eligibility of the prescribers to prescribe GHB;  
 confirming with the patient that GHB educational material has been received and/or read prior to providing GHB to the patient a first time;  
 requiring checking of the exclusive computer database for potential GHB abuse associated with the patient;  
 mailing or sending by courier GHB to the patient only provided information in the exclusive computer database is not indicative of potential abuse by the patient to whom GHB is prescribed and the doctor prescribing the GHB;  
 confirming receipt by the patient of the GHB; and  
 generating with the computer processor periodic reports via the exclusive computer database to evaluate potential GHB diversion patterns.

12

**14.** A computerized method of distributing a prescription drug under control of an exclusive central pharmacy, the method comprising:

receiving in a computer processor all prescription requests, for any and all patients being prescribed the prescription drug, only at the central pharmacy from any and all authorized prescribers allowed to prescribed the prescription drug, the prescription requests containing information identifying patients, the prescription drug, and various credentials of the any and all authorized prescribers;  
 entering the information into an exclusive computer database under exclusive control of the central pharmacy for analysis of potential abuse situations, wherein the use of the exclusive computer database is required for distribution of the prescription drug, such that all prescriptions for the prescription drug are processed only by the exclusive central pharmacy using only the exclusive computer database;  
 checking with the computer processor the credentials of the any and all authorized prescribers to determine the eligibility of the prescribers to prescribe the prescription drug;  
 confirming with the patient that educational material has been received and/or read prior to providing the prescription drug to the patient;  
 requiring checking of the exclusive computer database for potential abuse by the patient to whom the prescription drug is prescribed and the authorized prescriber allowed to prescribe the prescription drug;  
 providing the prescription drug to the patient only provided information in the exclusive computer database is not indicative of potential abuse by the patient to whom the prescription drug is prescribed and the authorized prescriber allowed to prescribe the prescription drug; and  
 confirming receipt by the patient of the prescription drug.

**15.** The computerized method of claim 14, wherein providing the prescription drug to the patient comprises the central pharmacy authorizing the prescription drug to be dispensed to the patient by another pharmacy.

**16.** The computerized method of claim 15, wherein the another pharmacy places controls on the distribution of the prescription drug, the controls selected from the group consisting of confirming with the patient that the educational material has been received and/or read by the patient, confirming receipt of the prescription drug by the patient, contacting the patient's insurance company, questioning early refill requests by the patient, flagging repeat instances of lost, stolen, destroyed or spilled prescriptions, flagging that the patient paid cash for the prescription drug, flagging early requests to refill the prescription drug, and limiting the prescription to a supply of limited duration.

\* \* \* \* \*



UNITED STATES PATENT AND TRADEMARK OFFICE  
**CERTIFICATE OF CORRECTION**

PATENT NO. : 7,895,059 B2  
APPLICATION NO. : 12/704097  
DATED : February 22, 2011  
INVENTOR(S) : Dayton T. Reardan et al.

Page 1 of 2

It is certified that error appears in the above-identified patent and that said Letters Patent is hereby corrected as shown below:

On page 2, under "US Patent Documents", in column 1, line 1, delete "Reardon" and insert -- Reardan --, therefor.

On Sheet 9 of 16, above Box 1, Figure 6, delete reference numeral "236" and insert -- 610 --, therefor. (Drawing sheet attached.)

On Sheet 9 of 16, above Box 2, Figure 6, delete reference numeral "236" and insert -- 620 --, therefor. (Drawing sheet attached.)

On Sheet 9 of 16, above Box 3, Figure 6, delete reference numeral "236" and insert -- 630 --, therefor. (Drawing sheet attached.)

On Sheet 9 of 16, above Box 4, Figure 6, delete reference numeral "350" and insert -- 640 --, therefor. (Drawing sheet attached.)

On Sheet 12 of 16, Figure 11, line 14, delete "XYREEM" and insert -- XYREM® --, therefor.

On Sheet 14 of 16, Figure 13A, line 26, delete "Rx/ENROLLEMENT" and insert --Rx/ENROLLMENT --, therefor.

In column 1, line 28, delete "buterate" and insert -- butyrate --, therefor.

In column 3, line 33, delete "Xyrem," and insert -- Xyrem®, --, therefor.

In column 4, line 14, delete "Xyrem." and insert -- Xyrem®. --, therefor.

In column 6, line 1, delete "Xyrem," and insert -- Xyrem®, --, therefor.

Signed and Sealed this  
Thirty-first Day of May, 2011



David J. Kappos  
*Director of the United States Patent and Trademark Office*

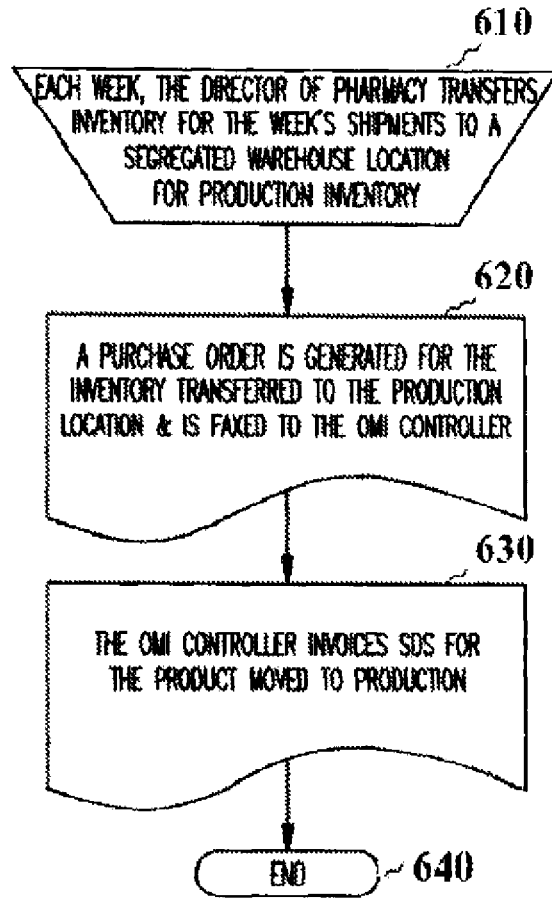

FIG. 6

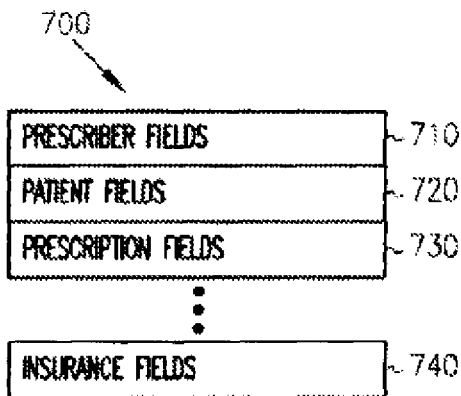

FIG. 7

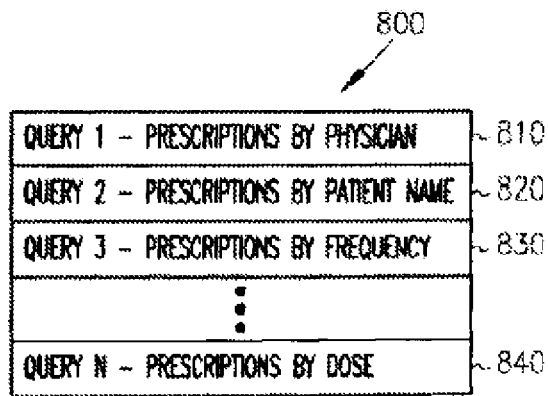

FIG. 8